

Table of Contents

SECTION 1 - SAFETY INFORMATION..... 1	3.1 USE AN ADEQUATE TOW VEHICLE AND HITCH 32
1.1 SAFETY ALERT SYMBOLS AND SIGNAL WORDS..... 1	3.1.1 <i>Trailer Information</i> 32
1.2 MAJOR HAZARDS 1	3.1.2 <i>Tow Vehicle</i> 33
1.2.1 <i>Improper Sizing of the Trailer to the Tow Vehicle.</i> 1	3.2 COUPLING AND UNCOUPLING THE TRAILER 34
1.2.2 <i>Driving Too Fast</i> 2	3.2.1 <i>Trailer with Ball Hitch Coupler</i> 35
1.2.3 <i>Failure to Adjust Driving Behavior When Towing a Trailer</i> 2	3.2.1.a Before Coupling the Trailer to Tow Vehicle..35
1.2.4 <i>Improper Loading</i> 2	3.2.1.b Prepare the Coupler and Hitch 36
1.2.5 <i>Trailer Not Properly Coupled to the Hitch</i> 2	3.2.1.c Couple the Trailer to the Tow Vehicle 36
1.2.6 <i>Proper Use of Safety Chains</i> 3	3.2.1.d Rig the Safety Chains 37
1.2.7 <i>Proper Connection of Breakaway Brake</i> 3	3.2.1.e Attach and Test the Breakaway Brake System37
1.2.8 <i>Matching Trailer and Hitch</i> 3	3.2.1.f Connect the Electrical Cables..... 38
1.2.9 <i>Worn Tires, Loose Wheels and Lug Nuts</i> 3	3.2.1.g Uncoupling the Ball Hitch Trailer 38
1.2.10 <i>Weight And Load Distribution</i> 4	3.2.2 <i>Trailer with Gooseneck Coupler and Drop-Leg Jack</i> 39
1.2.11 <i>Shifting Cargo</i> 5	3.2.2.a Adjust Gooseneck Hitch Height 39
1.2.12 <i>Inappropriate Cargo</i> 5	3.2.2.b Drop-Leg Jack(s)..... 40
1.2.13 <i>Inoperable Brakes, Lights or Mirrors</i> 5	3.2.2.c Before Coupling the Trailer to Tow Vehicle..40
1.2.14 <i>Hazards From Modifying Your Trailer</i> 6	3.2.2.d Prepare the Ball Receiver and Gooseneck Ball41
1.2.15 <i>Hazards from Accessories</i> 6	3.2.2.e Couple the Trailer to the Tow Vehicle 41
1.2.16 <i>Generator</i> 6	3.2.2.f Rig the Safety Chains 41
1.2.17 <i>Shore Power</i> 6	3.2.2.g Attach and Test the Breakaway Brake System42
1.2.18 <i>LP Gas Fuel System</i> 7	3.2.2.h Connect the Electrical Cables..... 43
1.2.19 <i>Gas And Fuel Storage</i> 7	3.2.2.i Uncoupling the Gooseneck Trailer with Drop-Leg Jack 43
1.2.20 <i>Trailer Towing Guide</i> 8	3.2.3 <i>Trailer with Fifth Wheel Coupler and Drop-Leg Jack</i> 44
1.2.21 <i>Safe Trailer Towing Guidelines</i> 9	3.2.3.a Before Coupling the Trailer to Tow Vehicle..44
1.2.22 <i>Safety Warning Labels on Your Trailer</i> 10	3.2.3.b Adjust Hitch Height..... 45
1.2.23 <i>Reporting Safety Defects</i> 21	3.2.3.c Prepare the Fifth Wheel Coupler 45
SECTION 2 - TIRE SAFETY INFORMATION 22	3.2.3.d Couple the Trailer to the Tow Vehicle 45
2.1 TRAILER TIRE INFORMATION..... 22	3.2.3.e Attach and Test the Breakaway Brake System47
2.2 STORING YOUR VEHICLE WITHOUT REMOVING THE TIRES 23	3.2.3.f Connect the Electrical Cables..... 47
2.3 STEPS FOR DETERMINING CORRECT LOAD LIMIT – TRAILER 23	3.2.3.g Rig the Safety Chains 48
2.3.1 <i>Trailers 10,000 Pounds GVWR or Less</i> 24	3.2.3.h Uncoupling the Fifth Wheel Trailer 48
2.3.2 <i>Trailers Over 10,000 Pounds GVWR</i> 24	SECTION 4 - LOADING THE TRAILER..... 50
2.4 STEPS FOR DETERMINING CORRECT LOAD LIMIT – TOW VEHICLE..... 24	4.1 CHECKING TONGUE WEIGHT 51
2.5 GLOSSARY OF TIRE TERMINOLOGY..... 24	4.2 LOADING CARGO 51
2.6 TIRE SAFETY - EVERYTHING RIDES ON IT 27	4.2.1 <i>Preparing the Trailer for Loading</i> 52
2.6.1 <i>Safety First–Basic Tire Maintenance</i> 27	4.2.2 <i>Loading the Trailer</i> 52
2.6.2 <i>Finding Your Vehicle's Recommended Tire Pressure and Load Limits</i> 27	4.3 SECURING THE CARGO 53
2.6.3 <i>Understanding Tire Pressure and Load Limits</i> 27	SECTION 5 - CHECKING THE TRAILER BEFORE AND DURING EACH TOW 54
2.6.4 <i>Checking Tire Pressure</i> 28	5.1 PRE-TOW CHECKLIST 54
2.6.5 <i>Steps for Maintaining Proper Tire Pressure</i> ... 28	5.2 MAKE REGULAR STOPS..... 54
2.6.6 <i>Tire Size</i> 28	SECTION 6 - BREAKING-IN A NEW TRAILER.... 55
2.6.7 <i>Tire Tread</i> 28	6.1 RETIGHTEN LUG NUTS AT FIRST 10, 25 & 50 MILES55
2.6.8 <i>Tire Balance and Wheel Alignment</i> 28	6.2 ADJUST BRAKE SHOES AT FIRST 200 MILES 55
2.6.9 <i>Tire Repair</i> 28	6.3 SYNCHRONIZING THE BRAKE SYSTEMS..... 55
2.6.10 <i>Tire Fundamentals</i> 29	6.4 TIRE PRESSURE 55
2.6.10.a Information on Passenger Vehicle Tires..... 29	SECTION 7 - ACCESSORIES 56
2.6.10.b UTQGS Information..... 29	7.1 GASOLINE OR DIESEL-POWERED ELECTRIC GENERATORS 56
2.6.10.c Information on Light Truck (LT) Tires 30	7.2 ACCESSORY BATTERY 56
2.6.10.d Information on Special Trailer (ST) Tires 30	7.3 SHORE POWER 56
2.6.11 <i>Tire Safety Tips</i> 30	7.4 LP GAS FUEL SYSTEM 57
SECTION 3 - COUPLING TO THE TOW VEHICLE32	7.4.1 <i>LP Gas System Troubleshooting</i> 58
	7.5 VENDING & ACCESSORY DOORS..... 58

Table of Contents

7.6	ELECTRIC- POWERED LANDING GEAR.....	58
SECTION 8 - INSPECTION, SERVICE & MAINTENANCE.....59		
8.1	INSPECTION, SERVICE & MAINTENANCE SUMMARY CHARTS	59
8.2	INSPECTION AND SERVICE INSTRUCTIONS	61
8.2.1	<i>Axle Bolts, Frame, Suspension, & Structure</i>	61
8.2.2	<i>Trailer Structure</i>	61
8.2.2.a	Fasteners and Frame Members	61
8.2.2.b	Welds.....	61
8.2.3	<i>Drop Ramp Torsion Springs</i>	62
8.2.4	<i>Slide-Outs</i>	62
8.2.5	<i>Trailer Brakes</i>	62
8.2.5.a	Initial Inspection	62
8.2.5.b	Periodic Inspection	62
8.2.5.c	Manually Adjusting Brake Shoes	62
8.2.5.d	Brakes, Electric.....	63
8.2.5.e	Brakes, Hydraulic (Air or Electric Operated) ..	63
8.2.6	<i>Trailer Connection to Tow Vehicle</i>	63
8.2.6.a	Coupler and Ball.....	63
8.2.6.b	Gooseneck	64
8.2.6.c	Fifth Wheel Kingpin.....	64
8.2.7	<i>Landing Leg or Jack</i>	64
8.2.8	<i>Lights and Signals</i>	64
8.2.9	<i>Accessory Battery</i>	64
8.2.10	<i>Tires</i>	64
8.2.11	<i>Wheel Rims</i>	64
8.2.12	<i>Wheel Liners (Simulators)</i>	65
8.2.13	<i>Wheel Bearings</i>	65
8.2.13.a	Standard Bearings.....	65
8.2.13.b	E-Z Lube® or Other Grease Fitting Lubricated Bearings	66
8.2.13.c	Nev-R-Lube™ or Other Sealed Bearings	66
8.2.14	<i>Lug Nuts (Bolts)</i>	66
SECTION 9 - TECHNICAL REFERENCE69		
9.1	TRAILER LIGHTING ELECTRICAL CONNECTION	69
9.2	HITCH SYSTEMS	71
SECTION 10 - WARRANTY72		

WARNING

This User's Manual contains safety information and instructions for your trailer.

You must read this manual before loading or towing your trailer.

You must follow all safety precautions and instructions.

“Portions of this manual were used with the expressed authority of Dexter Axle, but Dexter Axle is not responsible for the accuracy of the information contained herein.”

Section 1 - SAFETY INFORMATION

1.1 SAFETY ALERT SYMBOLS AND SIGNAL WORDS

This manual provides instructions for the operation and care of Haulmark Enclosed Trailers. The instructions in this manual must be followed to ensure the safety of persons and cargo, and satisfactory life of the trailer. Safety precautions to protect against injury or property damage must be followed at all times.

An Owner's Manual that provides general trailer information cannot cover all of the specific details necessary for the proper combination of every trailer, tow vehicle and hitch. Therefore, you must read, understand and follow the instructions given by the tow vehicle and trailer hitch manufacturers, as well as the instructions in this manual.

Our trailers are built with components produced by various manufacturers. Some of these items have separate instruction manuals. Where this manual indicates that you should read another manual, and you do not have that manual, call Haulmark Industries Inc. at 800-348-7530 or your dealer for assistance.

The safety information in this manual is denoted by the safety alert symbol: 

The level of risk is indicated by the following signal words.

 DANGER
DANGER – Immediate hazards which WILL result in severe personal injury or death if the warning is ignored.

 WARNING
WARNING – Hazards or unsafe practices which COULD result in severe personal injury or death if the warning is ignored.

 CAUTION
CAUTION – Hazards or unsafe practices which could result in minor or moderate injury if the warning is ignored.

NOTICE

NOTICE – Practices that could result in damage to the trailer or other property.

1.2 MAJOR HAZARDS

Loss of control of the trailer or trailer/tow vehicle combination can result in death or serious injury. The most common causes for loss of control of the trailer are:

- Improper sizing the trailer for the tow vehicle, or vice versa.
- Excessive Speed: Driving too fast for the conditions.
- Failure to adjust driving behavior when towing a trailer.
- Overloading and/or improper weight distribution.
- Improper or mis-coupling of the trailer to the hitch.
- Improper braking and steering under sway conditions.
- No brakes on trailer, if trailer is originally equipped with brakes.
- Not maintaining proper tire pressure.
- Not keeping lug nuts tight.

1.2.1 Improper Sizing of the Trailer to the Tow Vehicle.

Trailers that weigh too much for the towing vehicle can cause stability problems, which can lead to death or serious injury. Furthermore, the additional strain put on the engine and drive-train may lead to serious tow vehicle maintenance problems. For these reasons the maximum towing capacity of your towing vehicle should not be exceeded. The towing capacity of your tow vehicle, in terms of maximum Gross Trailer Weight (GTW) and maximum Gross Combined Weight Rating (GCWR) can be found in the tow vehicles Owner's Manual.

 DANGER
Use of an under-rated hitch, ball or tow vehicle can result in loss of control leading to death or serious injury.
Make certain your hitch and tow vehicle are rated for your trailer.

Section 1 - Safety Information

1.2.2 Driving Too Fast

With ideal road conditions, the maximum recommended speed for safely towing a trailer is 60 mph. If you drive too fast, the trailer is more likely to sway, thus increasing the possibility for loss of control. Also your tires may overheat, thus increasing the possibility of a blowout.

WARNING

Driving too fast for conditions can result in loss of control and cause death or serious injury.

Adjust speed down when towing trailer.

1.2.3 Failure to Adjust Driving Behavior When Towing a Trailer

When towing a trailer, you will have decreased acceleration, increased stopping distance, and increased turning radius (which means you must make wider turns to keep from hitting curbs, vehicles, and anything else that is on the inside corner). Furthermore, the trailer will change the handling characteristics of your towing vehicle, making it more sensitive to steering inputs and more likely to be pushed around in windy conditions or when being passed by large vehicles. In addition, you will need a longer distance to pass, due to slower acceleration and increased length. With this in mind:

- Be alert for slippery conditions. You are more likely to be affected by slippery road surfaces when driving a tow vehicle with a trailer, than driving a tow vehicle without a trailer.
- Anticipate the trailer “swaying.” Swaying can be caused by excessive steering, wind gusts, roadway edges, or by the trailer reaction to the pressure wave created by passing trucks and busses.
- When encountering trailer sway, take your foot off the accelerator, and steer as little as possible in order to stay on the road. Use small “trim-like” steering adjustments. Do not attempt to steer out of the sway; you’ll only make it worse. Also, do not apply the tow vehicle brakes to correct trailer swaying. The application of the trailer brakes alone will tend to straighten out the combination, especially when going downhill.
- Check rearview mirrors frequently to observe the trailer and traffic.
- Use lower gear when driving down steep or long grades. Use the engine and transmission as a brake. Do not ride the brakes, as they can overheat and become ineffective.
- Be aware of your trailer height, especially when approaching bridges, roofed areas and around trees.

1.2.4 Improper Loading

The total weight of the load you put in or on the trailer, plus the empty weight of the trailer itself, must not exceed the trailer's Gross Vehicle Weight Rating (GVWR). If you do not know the empty weight of the trailer, you must measure it at a commercial scale. In addition, you must distribute the load in the trailer such that the load on any axle does not exceed the Gross Axle Weight Rating (GAWR). The GVWR and GAWR's are listed on the Certification / VIN label mounted on the front left side of the trailer.

WARNING

An overloaded trailer can result in failure or in loss of control of the trailer, leading to death or serious injury.

Never load a trailer so that the weight on any tire exceeds its rating.

Never exceed the trailer Gross Vehicle Weight Rating (GVWR).

Never exceed an axle Gross Axle Weight Rating (GAWR).

1.2.5 Trailer Not Properly Coupled to the Hitch

It is critical that the trailer be securely coupled to the hitch, and that the safety chains and emergency breakaway brake lanyard are correctly attached. Uncoupling may result in death or serious injury to you and to others.

WARNING

Coupler and hitch selection and condition are critical for safe towing.

Uncoupling can result in death or serious injury.

- **Make sure the hitch and ball are rated for the trailer.**
- **Make sure the hitch [ball size] matches the coupler.**
- **Check the hitch ball for wear, corrosion and cracks before coupling. Replace worn, corroded or cracked hitch ball before coupling to the trailer.**
- **Make sure the hitch ball is tight to the hitch before coupling the trailer.**

Section 1 - Safety Information

WARNING

An improperly coupled trailer can result in death or serious injury.

Do not move the trailer until:

- The coupler is secured and locked;
- The safety chains are secured to the tow vehicle; and
- The trailer jacks are fully retracted.

Do not tow the trailer on the road until:

- The trailer brakes are checked;
- The breakaway switch is connected to the tow vehicle;
- The load is secured to the trailer; and
- The trailer lights are connected and checked.

1.2.6 Proper Use of Safety Chains

Safety chains are provided so that control of the trailer can still be maintained if the trailer comes loose from the tow vehicle for any reason.

WARNING

Incorrect rigging of the safety chains can result in loss of control of the trailer and tow vehicle, leading to death or serious injury, if the trailer uncouples from the tow vehicle.

Chains must:

- Fasten to frame of tow vehicle, not to hitch or ball.
- Cross underneath hitch and coupler with minimum slack to permit turning and to hold tongue up, if the trailer comes loose.

1.2.7 Proper Connection of Breakaway Brake

If equipped with brakes, your trailer will be equipped with a breakaway brake system that can apply the brakes on your trailer, if your trailer comes loose from the hitch for any reason. You will have a separate set of instructions for the breakaway brake if your trailer is so equipped. The breakaway brake system, including battery, must be in good condition and properly rigged to be effective.

WARNING

An ineffective breakaway brake system can result in a runaway trailer, leading to death or serious injury if the coupler or ball hitch fails.

Test the function of the breakaway brake system before towing the trailer. Do not tow the trailer if the breakaway brake system is not working; have it serviced or repaired.

Connect the breakaway lanyard to the tow vehicle -

NOT to the safety chain; and

NOT to the hitch, ball or support.

1.2.8 Matching Trailer and Hitch

DANGER

Use of an under-rated hitch, ball or tow vehicle can result in loss of control leading to death or serious injury.

Make certain your hitch and tow vehicle are rated for your trailer.

1.2.9 Worn Tires, Loose Wheels and Lug Nuts

Just as with your tow vehicle, the trailer tires and wheels are important safety items. Therefore, it is essential to inspect the trailer tires before each tow.

If a tire has a bald spot, bulge, cut, cracks, or is showing any cords, replace the tire before towing. If a tire has uneven tread wear, take the trailer to a dealer service center for diagnosis. Uneven tread wear can be caused by tire imbalance, axle misalignment or incorrect inflation.

Tires with too little tread will not provide adequate frictional forces on wet roadways and can result in loss of control, leading to death or serious injury.

Improper tire pressure causes increased tire wear and may reduce trailer stability, which can result in a tire blowout or possible loss of control. Therefore, before each tow you must also check the tire pressure. Remember, the proper tire pressure is listed on the Certification (VIN) label, and should be checked when tires are cold. Allow 3 hours cool-down after driving as much as 1 mile at 40 mph before checking tire pressure.

Section 1 - Safety Information

⚠ WARNING

Improper tire pressure may cause an unstable trailer. Blowout and loss of control may occur. Death or serious injury can result.

Make sure of proper tire pressure before towing trailer. Inflate tires to pressure indicated on Certification / VIN label.

The tightness of the lug nuts is very important in keeping the wheels properly seated to the hub.

Before each tow, check to make sure they are tightened to the proper torque.

⚠ WARNING

Metal creep between the wheel rim and lug nuts (bolts) will cause rim to loosen.

Death or injury can occur if wheel comes off.

Tighten lug nuts (bolts) before each tow.

The proper tightening sequence and tightness (torque) for lug nuts is listed in the "Inspection, Service & Maintenance" chapter of this manual. Use a calibrated torque wrench to tighten the lug nuts.

Lug nuts are also prone to loosen after first being assembled. When driving a new trailer (or after wheels have been remounted), check to make sure they are tightened to the proper torque after the **first** 10, 25 and 50 miles of driving and before each tow thereafter.

Failure to perform this check can result in a wheel parting from the trailer and a crash, leading to death or serious injury.

⚠ WARNING

Lug nuts are prone to loosen after being first assembled. Death or serious injury can result.

Check lug nuts for tightness on a new trailer, and after re-mounting a wheel at 10, 25 and 50 miles.

⚠ WARNING

Inadequate lug nut torque can cause a wheel to part while towing. Death or serious injury can result.

Make sure lug nuts are tight before towing trailer.

1.2.10 Weight And Load Distribution

Proper loading of your trailer is essential for your safety. Tire, wheel, axle or structural failure can be caused by overloading.

⚠ WARNING

An overloaded trailer can result in failure or in loss of control of the trailer, leading to death or serious injury.

Never load a trailer so that the weight on any tire exceeds its rating.

Never exceed the trailer Gross Vehicle Weight Rating (GVWR).

Never exceed an axle Gross Axle Weight Rating (GAWR).

Improper front / rear load distribution can lead to poor trailer sway stability or poor tow vehicle handling. Poor trailer sway stability results from tongue weights that are too low, and poor tow vehicle stability results from tongue weights that are too high.

In figure 1-1, the second column shows the rule of thumb percentage of total weight of the trailer, plus its cargo (Gross Trailer Weight, or "GTW") that should appear on the tongue of the trailer. For example, a trailer with a gooseneck hitch, with a loaded weight of 12,000 pounds, should have 20-25% of 12,000 pounds (2400-3000 lbs.) on the gooseneck. After loading, be sure to check that none of the axles are overloaded.

Approximate Tongue Weight as a Percentage of Loaded Trailer Weight	
Type of Hitch	Percentage
Ball Hitch (or Bumper Hitch)	15%
Gooseneck Hitch	20-25%
Fifth Wheel Hitch	

Tongue Weight Chart - Figure 1-1

Section 1 - Safety Information

Uneven left / right load distribution can cause tire, wheel, axle or structural failure. Be sure your trailer is evenly loaded left / right.

Towing stability also depends on keeping the center of gravity as low as possible.

⚠ WARNING

An improperly distributed load can result in loss of control of the trailer, and can lead to death or serious injury.

Proper tongue weight is essential for stable trailer handling.

Distribute the load front to rear to provide proper tongue weight.

Distribute the load evenly, right and left, to avoid tire overload.

Keeping the center of gravity low and centered is essential to minimize the risk of tip-over.

1.2.11 Shifting Cargo

Since the trailer “ride” can be bumpy and rough, you must secure your cargo so that it does not shift while the trailer is being towed.

⚠ WARNING

A shifting load can result in failure, or to loss of control of the trailer, and can lead to death or serious injury.

You must tie down all loads with proper sized fasteners, ropes, straps, etc. to prevent the load from shifting while trailering.

If the door latch is equipped with a catch that has a hole for a linchpin, use a linchpin to prevent the door latch from opening.

⚠ WARNING

Always secure the door latch after closing. Place a linchpin in the catch.

If the door opens, your cargo may be ejected onto the road, resulting in death or serious injury to the animals or other drivers.

1.2.12 Inappropriate Cargo

Your trailer may be designed for specific cargo, for example, only for horses. If your trailer is designed for specific cargo, only carry that cargo in the trailer. Your trailer must not be used to carry certain items, such as people, containers of hazardous substances or containers of flammable substances. A trailer not designed with living quarters should only be used for transportation of its intended cargo.

⚠ DANGER

You can die or be brain damaged by Carbon Monoxide.

Do not operate a generator, portable grills, portable heaters, portable lanterns or portable stoves inside the trailer.

⚠ WARNING

Never transport people inside your Haulmark trailer, even if it has living quarters. Besides putting their lives at risk, the transport of people may be illegal.

⚠ WARNING

Do not sleep in a trailer not equipped with living quarters.

A trailer not designed with living quarters should only be used for transportation of its intended cargo.

⚠ WARNING

Your Haulmark trailer is not capable of safely transporting flammable, explosive, poisonous or other dangerous materials.

1.2.13 Inoperable Brakes, Lights or Mirrors

Be sure that the brakes (if equipped) and all of the lights on your trailer are functioning properly before towing your trailer. Electric brakes and lights on a trailer are controlled via a connection to the tow vehicle, generally a multi-pin electrical connector. Check the trailer taillights by turning on your tow vehicle headlights. Check the trailer brake lights by having someone step on the tow vehicle brake pedal while you look at trailer lights. Check the turn signal lights by operating the turn signal lever in the tow vehicle.

Section 1 - Safety Information

If your trailer has electric brakes, your tow vehicle will have an electric brake controller that sends power to the trailer brakes. Before towing the trailer on the road, you must operate the brake controller while trying to pull the trailer in order to confirm that the electric brakes operate. While towing the trailer at less than 5 mph, manually operate the electric brake controller in the tow vehicle cab. You should feel the operation of the trailer brakes.

WARNING

Failure to connect the tow vehicle lighting and braking to the trailer will result in inoperable lights and brakes, and can lead to collision.

Check that all the trailer lights and brakes work before each tow.

If your trailer has hydraulic “surge” brakes, pull the emergency breakaway brake lanyard to check the operation of the surge mechanism.

Standard mirrors usually do not provide adequate visibility for viewing traffic to the sides and rear a towed trailer. You must provide mirrors that allow you to safely observe approaching traffic.

1.2.14 Hazards From Modifying Your Trailer

Essential safety items and structural integrity can be damaged by altering your trailer. Even simply driving a nail or screw can damage an electrical circuit, LP gas line or other feature of the trailer.

Before making any alteration to your trailer, contact your dealer or Haulmark Industries, Inc. at 800-348-7530 and describe the alteration you are contemplating. Alteration of the trailer structure or modification of mechanical, electrical, plumbing, heating or other systems on your trailer must be performed only by qualified technicians who are familiar with the system as installed on your trailer.

1.2.15 Hazards from Accessories

The “Accessories” chapter of this manual contains some information about certain optional accessories that may be on your trailer. Read and follow all of these instructions before operating the accessories. The major hazards from some of these accessories are:

1.2.16 Generator

If your trailer is equipped with a gasoline or diesel generator, you must have and follow the generator manufacturer’s instructions. You must also have one or

more carbon monoxide detectors in the trailer’s accommodation spaces.

Carbon Monoxide is an odorless gas that can cause death. Be certain exhaust from a running generator does not accumulate in or around your trailer, by situations such as:

- Being drawn in by fans or ventilators operated in a trailer;
- Prevailing wind;
- Being trapped between your trailer and other trailers, vehicles or buildings; or
- Being trapped between your trailer and, or in a snow bank, or other nearby objects

WARNING

Gasoline and diesel generators pose a risk of death from:

- **Carbon Monoxide**
- **Fire and Explosion**
- **Electrocution**

Do not operate a generator without having a working carbon monoxide detector.

Do not refuel a running generator.

Do not refuel near ignition sources.

1.2.17 Shore Power

“Shore Power” is the name given to connecting your trailer to a source of electrical power using a cord specifically designed for that purpose.

WARNING

Shore power poses a risk of death due to electrocution.

Always use a grounded connection.

Never connect to an ungrounded source of shore power.

Never remove the “third prong” from the shore power plug.

Section 1 - Safety Information

WARNING

Risk of fire.

Connect only to source of correct voltage.

Do not overload electrical circuits.

Do not use an extension cord to connect to shore power.

Replace fuses with like rating.

1.2.18 LP Gas Fuel System

DANGER

You can die or be brain damaged by Carbon Monoxide.

Make certain the exhaust from LP appliances is directed to the outdoors.

Have a working carbon monoxide detector in the accommodation spaces of your trailer before operating any LP gas appliance.

Do not operate portable grills, portable stoves, portable lanterns or portable heaters inside the trailer.

WARNING

Risk of death due to fire or explosion.

Do not connect an LP gas system to a supply of natural gas.

Extinguish all pilot lights and turn off all appliances before refilling fuel or LP gas tanks.

Do not fill the tank with any gas other than LP (butane or propane).

Do not store LP gas tanks inside the trailer.

WARNING

Risk of fire or explosion

If LP gas is detected (by smell or by the LP gas detector):

- Do not touch electrical switches
- Extinguish flames and pilot lights
- Open doors for ventilation
- Shut off LP gas supply at the LP tank
- Leave the area until odor clears

Correct the source of LP gas leakage before using LP appliances.

Do not use a flame to locate the source of an LP gas leak.

1.2.19 Gas And Fuel Storage

WARNING

Do not transport flammable explosive, poisonous or other dangerous materials in your trailer. Exceptions:

- Fuel in the tanks of vehicles that are being towed
- Fuel stored in proper containers used in trailer living quarters for cooking

Fuel stored in the tank of an on-board generator

WARNING

Accumulation of hazardous fumes can cause death or serious injury.

Do not block access to ventilation ports.

Section 1 - Safety Information

WARNING

Gasoline and diesel generators pose a risk of death from:

- Carbon Monoxide
- Fire and Explosion
- Electrocutation

Do not operate a generator without having a working carbon monoxide detector.

Do not refuel a running generator.

Do not refuel near ignition sources.

WARNING

Shore power poses a risk of death due to electrocution or fire

Always use an electrical cord specifically designed for shore power connection. Never use an ordinary extension cord.

Always connect the electrical cord to a grounded source of shore power.

Do not remove the “third prong” from the shore power plug.

Connect only to source of proper voltage.

Make certain polarity is correct.

Do not overload electrical circuits.

Always replace fuses or circuit breakers with correct rating.

WARNING

Risk of fire or explosion Never use a flame, heat lamp or hair dryer to thaw an LP gas regulator. Use an incandescent light bulb.

Do not remove the regulator cover of attempt to service the LP gas regulator.

WARNING

Do not transport flammable explosive, poisonous or other dangerous materials in your trailer. Exceptions:

- Fuel in the tanks of vehicles that are being towed
- Fuel stored in proper containers used in trailer living quarters for cooking

Fuel stored in the tank of an on-board generator

1.2.20 Trailer Towing Guide

Driving a vehicle with a trailer in tow is vastly different from driving the same vehicle without a trailer in tow. Acceleration, maneuverability and braking are all diminished with a trailer in tow. It takes longer to get up to speed, you need more room to turn and pass, and more distance to stop when towing a trailer. You will need to spend time adjusting to the different feel and maneuverability of the tow vehicle with a loaded trailer. Because of the significant differences in all aspects of maneuverability when towing a trailer, the hazards and risks of injury are also much greater than when driving without a trailer. You are responsible for keeping your vehicle and trailer in control, and for all the damage that is caused if you lose control of your vehicle and trailer.

As you did when learning to drive an automobile, find an open area with little or no traffic for your first practice trailering. Of course, before you start towing the trailer, you must follow all of the instructions for inspection, testing, loading and coupling. Also, before you start towing, adjust the mirrors so you can see the trailer as well as the area to the rear of it.

Drive slowly at first, 5 m.p.h. or so, and turn the wheel to get the feel of how the tow vehicle and trailer combination responds. Next, make some right and left hand turns. Watch in your side mirrors to see how the trailer follows the tow vehicle. Turning with a trailer attached requires more room.

Stop the rig a few times from speeds no greater than 10 m.p.h. If your trailer is equipped with brakes, try using different combinations of trailer/electric brake and tow vehicle brake. Note the effect that the trailer brakes have when they are the only brakes used. When properly adjusted, the trailer brakes will come on just before the tow vehicle brakes.

It will take practice to learn how to back up a tow vehicle with a trailer attached. Take it slow. Before backing up, get out of the tow vehicle and look behind the trailer to make sure that there are no obstacles. Some

Section 1 - Safety Information

drivers place their hands at the bottom of the steering wheel, and while the tow vehicle is in reverse, “think” of the hands as being on the top of the wheel. When the hands move to the right (counter-clockwise, as you would do to turn the tow vehicle to the left when moving forward), the rear of the trailer moves to the right. Conversely, rotating the steering wheel clockwise with your hands at the bottom of the wheel will move the rear of the trailer to the left, while backing up. If you are towing a bumper hitch rig, be careful not to allow the trailer to turn too much, because it will hit the rear of the tow vehicle. To straighten the rig, either pull forward, or turn the steering wheel in the opposite direction.

1.2.21 Safe Trailer Towing Guidelines

- Recheck the load tiedowns to make sure the load will not shift during towing.
- Before towing, check coupling, safety chain, safety brake, tires, wheels and lights.
- Check the lug nuts or bolts for tightness.
- Check coupler tightness after towing 50 miles.
- Adjust the brake controller to engage the trailer brakes before the tow vehicle brakes. Your dealer can assist you by making this adjustment.
- Use your mirrors to verify that you have room to change lanes or pull into traffic.
- Use your turn signals well in advance.
- Allow plenty of stopping space for your trailer and tow vehicle.
- Do not drive so fast that the trailer begins to sway due to speed. Never drive faster than 60 m.p.h.
- Allow plenty of room for passing. A rule of thumb is that the passing distance with a trailer is 4 times the passing distance without a trailer.
- Shift your automatic transmission into a lower gear for city driving.
- Use lower gears for climbing and descending grades.
- Do not ride the brakes while descending grades, they may get so hot that they stop working. Then you will potentially have a runaway tow vehicle and trailer.
- To conserve fuel, don't use full throttle to climb a hill. Instead, build speed on the approach.
- Slow down for bumps in the road. Take your foot off the brake when crossing the bump.
- Do not brake while in a curve unless absolutely necessary. Instead, slow down before you enter the curve and power through the curve. This way, the towing vehicle remains “in charge.”
- Do not apply the brakes to correct extreme trailer swaying. The application of the trailer brakes alone will tend to straighten out the combination, especially when going downhill.
- Make regular stops, about once each hour. Confirm that
 - the coupler is secure to the hitch and is locked,
 - electrical connectors are made,
 - there is appropriate slack in the safety chains,
 - there is appropriate slack in the breakaway switch pullpin lanyard,
 - the tires are not visibly low on pressure, and
 - the cargo is secure and in good condition.

Section 1 - Safety Information

1.2.22 Safety Warning Labels on Your Trailer

Check your Haulmark trailer for the warning and instruction labels on the following pages. Many of those listed are mandated by the U. S. government and others will help you in the safe operation of your trailer. The following information is provided in the event that any of the labels are missing.

Federal Certification/VIN plate mounted on driver side of trailer

MANUFACTURED BY / FABRIQUE PAR: Haulmark Ind., Inc.		DATE:	
P.O. Box 281 Bristol IN 46507-0281 (574) 825-5867			
GVWR/PMBV	KG (LB)	TIRES/PNEU	RIMS/JANTE
FRONT/ AVANT	KG (LB)		COLD INFL. PRESS./PRESS. DE CONFL. A FROID KPA SINGLE DUAL PSI(LFC) <input type="checkbox"/> <input type="checkbox"/>
INTERM/ INTERM	KG (LB)		KPA SINGLE DUAL PSI(LFC) <input type="checkbox"/> <input type="checkbox"/>
REAR/ ARRIERE	KG (LB)		KPA SINGLE DUAL PSI(LFC) <input type="checkbox"/> <input type="checkbox"/>
<small>THIS VEHICLE CONFORMS TO ALL APPLICABLE U.S. FEDERAL MOTOR VEHICLE SAFETY STANDARDS IN EFFECT ON THE DATE OF MANUFACTURE SHOWN ABOVE. THIS VEHICLE CONFORMS TO ALL APPLICABLE STANDARDS PRESCRIBED UNDER THE CANADIAN MOTOR VEHICLE SAFETY REGULATIONS IN EFFECT ON THE DATE OF MANUFACTURE. - CE VEHICULE EST CONFORME A TOUTES LES NORMES QUI LUI SONT APPLICABLES EN VERTU DU REGLEMENT SUR LA SECURITE DES</small>			
V.I.N./I.L.V.:		TYPE/TYPE: TRAILER	HA2099

Located on the driver side wall of trailer

TIRE AND LOADING INFORMATION

The weight of cargo should never exceed
Kg or Lbs.

TIRE	SIZE	COLD TIRE PRESSURE	SEE OWNER'S MANUAL FOR ADDITIONAL INFORMATION
FRONT			
REAR			
SPARE			

16HGB24265H130090

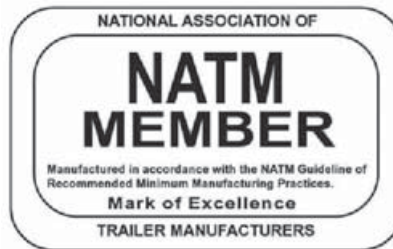

Located at transfer switch or junction box

GENERATOR CIRCUIT. THIS CONNECTION IS FOR GENERATORS RATED 110-125 vOLT AC, 60 HZ _____ AMPERES MAXIMUM

AIR-CONDITIONING CIRCUIT. THIS CONNECTION IS FOR AIR CONDITIONERS RATED 110-125 VOLT AC, 60 HZ _____ AMPERES MAXIMUM. DO NOT EXCEED CIRCUIT RATING. LD-101

Section 1 - Safety Information

Located outside power supply

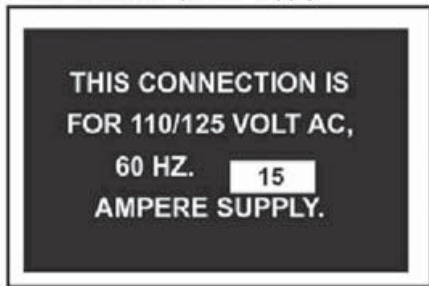
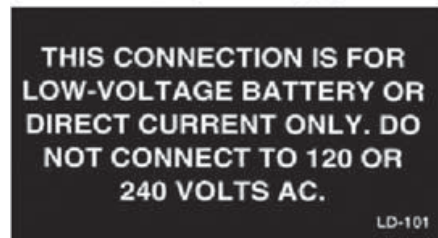
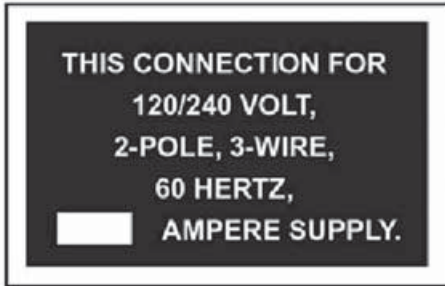
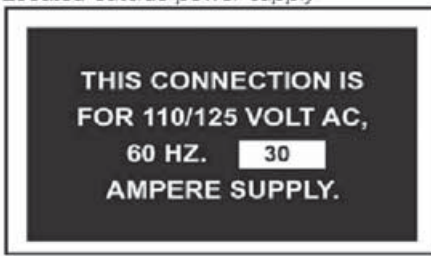

Located on battery box



Each Trip:
Disconnect electrical plug.
Pull breakaway pin.
Bright light-battery o.k.
No light-charge battery.
Try to pull forward,
.....

Section 1 - Safety Information

Located above fuel filter door/cap on trailers with tank for diesel fuel



Located on marine battery

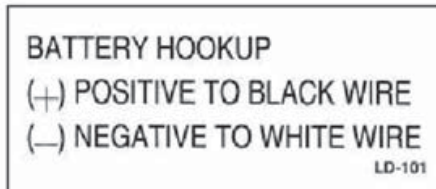

Located above fuel filter door/cap on trailers with tank for gasoline



Located on breakaway switch

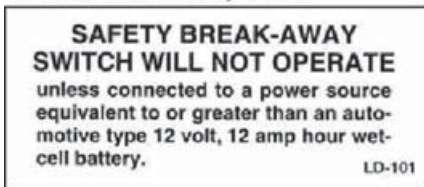

Located over side door



Section 1 - Safety Information

Located at LP tank on trailers with LP systems



Located next to tongue tag at front side

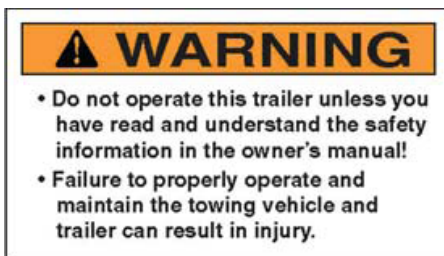

Mounted on round-top caps

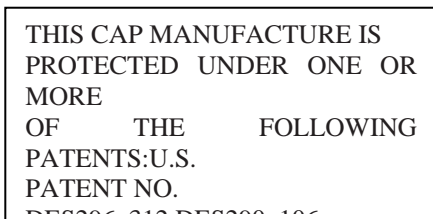

Located above stove

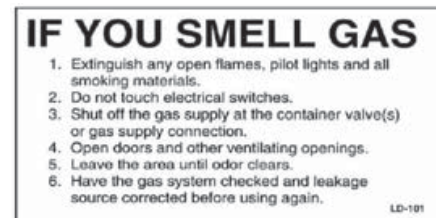

Located on walk-on roof platform

Section 1 - Safety Information



Roadside location inside trailer



Roadside location inside trailer indicating slippery ramp door



Located on all trailers with ladder racks and all Edge trailers



Located above doors with low openings



Section 1 - Safety Information

Located near all ramp doors



Located on or near generator



Located near awning door

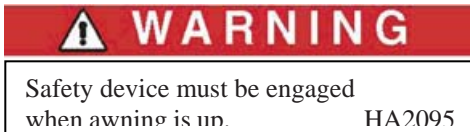

Located on all ramp doors

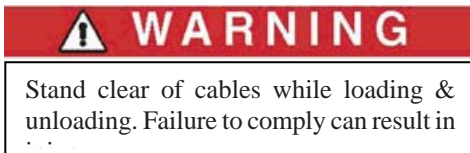

Located on or near slide-out generator

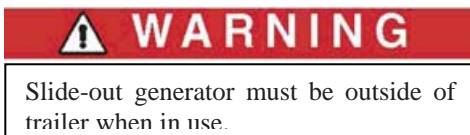

Section 1 - Safety Information

Located above water inlet on exterior, for trailers with city water connections



Located on roadside exterior



Located on roadside exterior



Located next to smoke detector

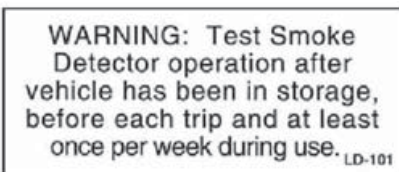

Located on all roof and luggage racks



Located on roof rack

Section 1 - Safety Information



Located on all roof and luggage racks

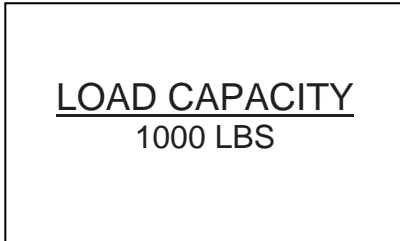

Located on roof rack



Located on electrical box cover of trailers with electrical connections

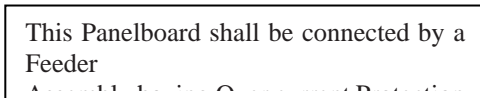

Located on interior sidewall of trailer

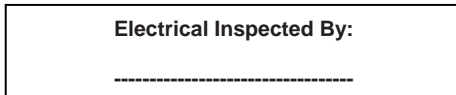

Located on swing-out lamp arm



Located inside closet door

Section 1 - Safety Information

WARNING

Any motorized vehicle or any motorized equipment powered with flammable liquid can cause fire or explosion or asphyxiation if stored or transported within the recreational vehicle. To reduce the risk of fire, explosion, or asphyxiation:

1. Do not allow passengers to ride inside internal combustion engine vehicle storage area while vehicles are present.
2. Doors and windows in walls of separation are to be closed while the vehicles are present.
3. Run fuel out of engine after shutting off fuel at the tank.
4. Do not store or transport supplementary motor fuel within this vehicle.
5. Ventilate the interior of the vehicle to reduce the risk of fire, explosion, or asphyxiation.
6. Do not operate gas appliances, pilot lights, or electrical equipment when motorized vehicles or motorized equipment are inside vehicle.

Stickers in location 1:

ICC

Tire and Loading Information (HA2006)

Overload Hazard Warning

Wheel Lug Tightness Notice

NATM

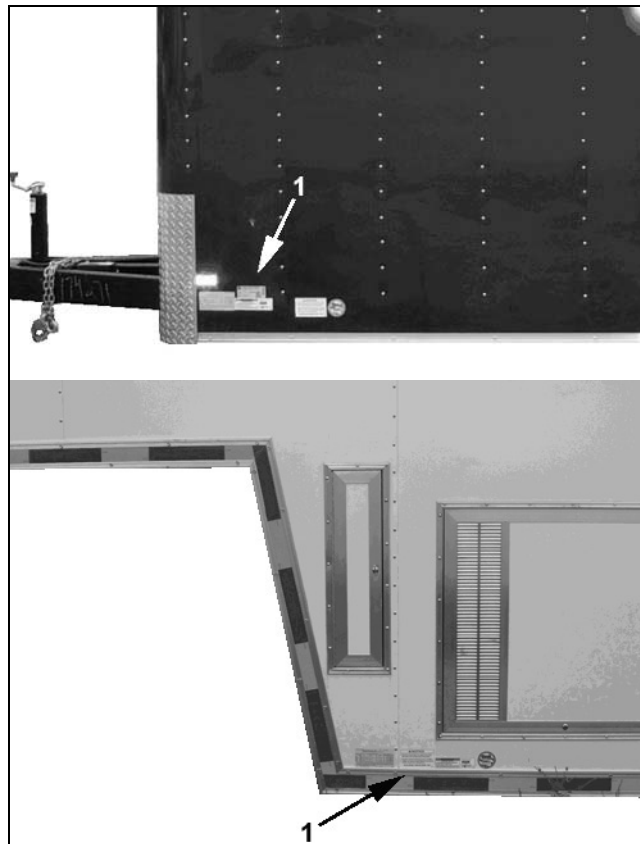

Warning Labels and Locations - Figure 1-1

Section 1 - Safety Information

Stickers in location 2:

OK to Ship / Inspection

Read Owner's Manual Warning (HA2068)

Breakaway Battery Notice (HA2049) (on battery box, if applicable)

Breakaway Battery Care Instructions (HA2059) (on battery box, if applicable)

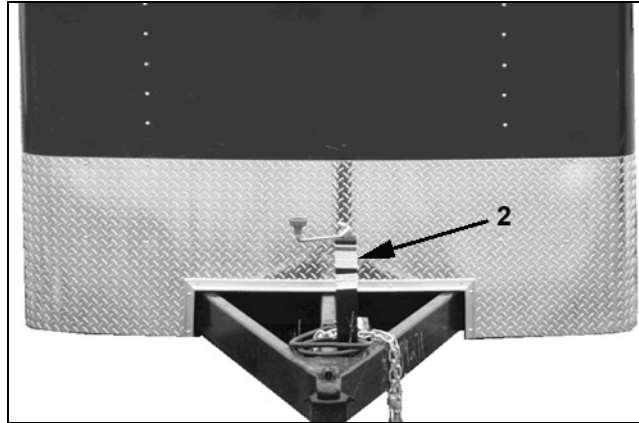

Warning Labels and Locations - Figure 1-2

Stickers in location 3:

Stand clear of cable warning (HA2047)

DANGER Heavy Door, Stand Clear (HA2067)

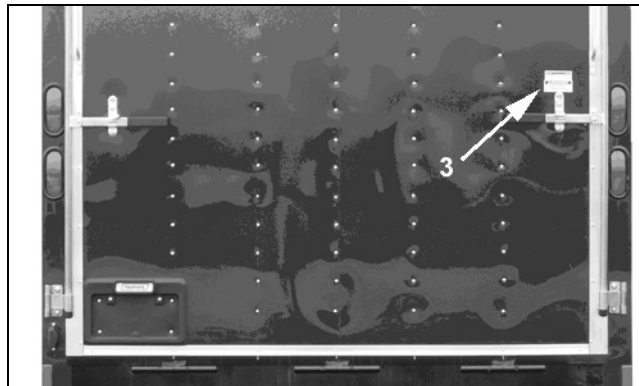

Warning Labels and Locations - Figure 1-3

Section 1 - Safety Information

Stickers in location 4:

OK to Ship / Inspection

Read Owner's Manual Warning (HA2068)

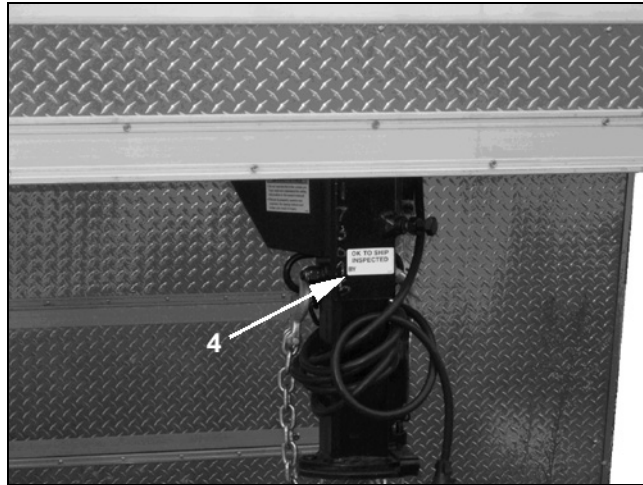

Warning Labels and Locations - Figure 1-4

Stickers in location 5:

DANGER Heavy Door, Stand Clear (HA2067) (2 places)

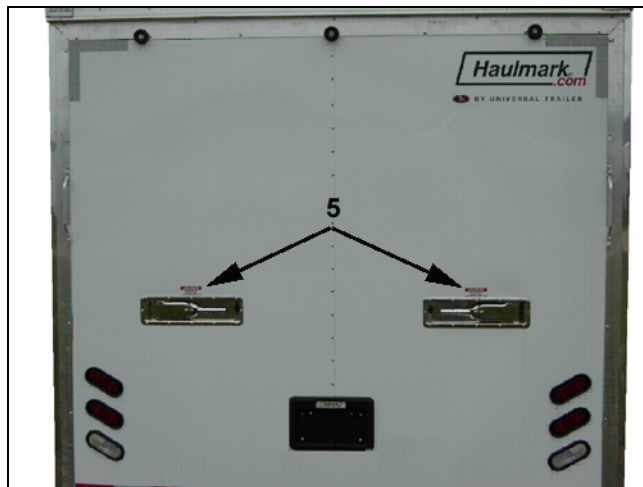

Warning Labels and Locations - Figure 1-5

Section 1 - Safety Information



WARNING

To protect you and others against death or serious injury, all of the labels shown above must be on the trailer and must be legible.

If any of these safety labels are missing or cannot be read, call Haulmark Industries Inc. at 800-348-7530 for free replacement labels.

You will need to provide us with the number shown at the bottom of the label(s) in order for us to send the correct one(s).

1.2.23 Reporting Safety Defects

If you believe that your vehicle has a defect that could cause a crash or could cause injury or death, you should immediately inform the National Highway Traffic Safety Administration (NHTSA) in addition to notifying us.

If NHTSA receives similar complaints, it may open an investigation, and if it finds that a safety defect exists in a group of vehicles, it may order a recall and remedy campaign. However, NHTSA cannot become involved in individual problems between you, your dealer, or us.

To contact NHTSA, you may either call the Vehicle Safety Hotline toll-free at 1-888-327-4236 (TTY: 1-800-424-9153), go to <http://www.safercar.gov>, or write to:

Administrator
NHTSA
1200 New Jersey Ave., SE
Washington, DC 20590.

You can also obtain other information about motor vehicle safety from <http://www.safercar.gov>.

Call 800-348-7530 to reach Haulmark Industries, Inc.

Section 2 - TIRE SAFETY INFORMATION

This portion of the User's Manual contains tire safety information as required by 49 CFR 575.6.

Section 2.1 contains "Trailer Tire Information"

Section 2.2 contains "Steps for Determining Correct Load Limit - Trailer".

Section 2.3 contains "Steps for Determining Correct Load Limit – Tow Vehicle".

Section 2.4 contains a Glossary of Tire Terminology, including "cold inflation pressure", "maximum inflation pressure", "recommended inflation pressure", and other non-technical terms.

Section 2.5 contains information from the NHTSA brochure entitled "Tire Safety – Everything Rides On It".

This brochure, as well as the preceding subsections, describes the following items;

- Tire labeling, including a description and explanation of each marking on the tires, and information about the DOT Tire Identification Number (TIN).
- Recommended tire inflation pressure, including a description and explanation of:
 - Cold inflation pressure.
 - Vehicle Placard and location on the vehicle.
 - Adverse safety consequences of under inflation (including tire failure).
 - Measuring and adjusting air pressure for proper inflation.
- Tire Care, including maintenance and safety practices.
- Vehicle load limits, including a description and explanation of the following items:
 - Locating and understanding the load limit information, total load capacity, and cargo capacity.
 - Calculating total and cargo capacities with varying seating configurations including quantitative examples showing / illustrating how the vehicles cargo and luggage capacity decreases as combined number and size of occupants' increases. This item is also discussed in Section 3.
 - Determining compatibility of tire and vehicle load capabilities.

- Adverse safety consequences of overloading on handling and stopping on tires.

2.1 TRAILER TIRE INFORMATION

Trailer tires may be worn out even though they still have plenty of tread left. This is because trailer tires have to carry a lot of weight all the time, even when not in use. It is actually better for the tire to be rolling down the road than to be idle. During use, the tire releases lubricants that are beneficial to tire life. Using the trailer tires often also helps prevent flat spots from developing.

The main cause of tire failure is improper inflation. Check the cold tire inflation pressures at least once a week for proper inflation levels. "Cold" means that the tires are at the same temperature as the surrounding air, such as when the vehicle has been parked overnight. Wheel and tire manufacturers recommend adjusting the air pressure to the trailer manufacturer's recommended cold inflation pressure, in pounds per square inch (PSI) stated on the vehicle's Federal Certification Label or Tire Placard when the trailer is loaded to its gross vehicle weight rating (GVWR). If the tires are inflated to less than the recommended inflation level or the GVWR of the trailer is exceeded, the load carrying capacity of the tire could be dramatically affected. If the tires are inflated more than the recommended inflation level, handling characteristics of the tow vehicle/trailer combination could be affected. Refer to the owner's manual or talk to your dealer or vehicle manufacturer if you have any questions regarding proper inflation practices.

Tires can lose air over a period of time. In fact, tires can lose 1 to 3 PSI per month. This is because molecules of air, under pressure, weave their way from the inside of the tire, through the rubber, to the outside. A drop in tire pressure could cause the tire to become overloaded, leading to excessive heat build up. If a trailer tire is under-inflated, even for a short period of time, the tire could suffer internal damage.

High speed towing in hot conditions degrades trailer tires significantly. As heat builds up during driving, the tire's internal structure starts to breakdown, compromising the strength of the tire. It is recommended to drive at moderate speeds.

Statistics indicate the average life of a trailer tire is about five years under normal use and maintenance conditions.

Section 2 - Tire Safety Information

After three years, replacing the trailer tires with new ones should be considered, even if the tires have adequate tread depth. Some experts claim that after five years, trailer tires are considered worn out and should be replaced, even if they have had minimal or no use. This is such a general statement that it may not apply in all cases. It is best to have your tires inspected by a tire supplier to determine if your tires need to be replaced.

2.2 STORING YOUR VEHICLE WITHOUT REMOVING THE TIRES

Ideally, a vehicle in storage should be placed on blocks to remove all weight from the tires. If the vehicle cannot be put on blocks, follow these steps for tire protection:

- Completely unload the vehicle so the minimum weight will be placed on the tires.
- Keep the tires inflated to recommended operating inflation pressure.
- Be sure the storage surface is firm, clean, well drained, and reasonably level.

Move the vehicle at least every three months to prevent ozone cracking in the tire bulge area as well as “flat spotting” from the prolonged strain of sidewall and tread deflection. Adjust inflation to recommended operating pressure before putting the vehicle back into service.

2.3 STEPS FOR DETERMINING CORRECT LOAD LIMIT – TRAILER

Determining the load limits of a trailer includes more than understanding the load limits of the tires alone. On all trailers there is a Federal Certification / VIN label that is located on the forward half of the left (road) side of the unit. This certification/VIN label will indicate the trailer’s Gross Vehicle Weight Rating (GVWR). This is the most weight the fully loaded trailer can weigh. It will also provide the Gross Axle Weight Rating (GAWR). This is the most a particular axle can weigh. If there are multiple axles, the GAWR of each axle will be provided.

If your trailer has a GVWR of 10,000 pounds or less, there is a vehicle placard located in the same location as the certification label described above. This placard provides tire and loading information. In addition, this placard will show a statement regarding maximum cargo capacity. Cargo can be added to the trailer, up to the maximum weight specified on the placard. The combined weight of the cargo is provided as a single number. In any case, remember: the total weight of a fully loaded trailer can not exceed the stated GVWR.

For trailers with living quarters installed, the weight of water and propane also need to be considered. The weight of fully filled propane containers is considered part of the weight of the trailer before it is loaded with cargo, and is not considered part of the disposable cargo load. Water however, is a disposable cargo weight and is treated as such. If there is a fresh water storage tank of 100 gallons, this tank when filled would weigh about 800 pounds. If more cargo is being transported, water can be off-loaded to keep the total amount of cargo added to the vehicle within the limits of the GVWR so as not to overload the vehicle. Understanding this flexibility will allow you, the owner, to make choices that fit your travel needs.

When loading your cargo, be sure it is distributed evenly to prevent overloading front to back and side to side. Heavy items should be placed low and as close to the axle positions as reasonable. Too many items on one side may overload a tire. The best way to know the actual weight of the vehicle is to weigh it at a public scale. Talk to your dealer to discuss the weighing methods needed to capture the various weights related to the trailer. This would include the weight empty or unloaded, weights per axle, wheel, hitch or king-pin, and total weight.

Excessive loads and/or underinflation cause tire overloading and, as a result, abnormal tire flexing occurs. This situation can generate an excessive amount of heat within the tire. Excessive heat may lead to tire failure. It is the air pressure that enables a tire to support the load, so proper inflation is critical. The proper air pressure may be found on the Certification / VIN label and/or on the Tire Placard. This value should never exceed the maximum cold inflation pressure stamped on the tire. It is recommended that your fully loaded vehicle (with any tow vehicles attached) be weighed to determine the tire loading at each wheel position. **Inflation** pressure should be adjusted to handle the maximum tire load, and all tires on the axle **should carry the same inflation pressure.** Tire pressure should be checked cold, or before driving each day, and at least once a month. Valves and caps should be free of dirt and moisture.

Section 2 - Tire Safety Information

2.3.1 Trailers 10,000 Pounds GVWR or Less

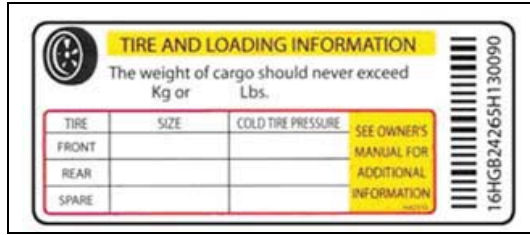

Tire Information Placard - Figure 2-1

1. Locate the statement, “The weight of cargo should never exceed XXX kg or XXX lbs.,” on your vehicle’s placard. See figure 2-1.
2. This figure equals the available amount of cargo and luggage load capacity.
3. Determine the combined weight of luggage and cargo being loaded on the vehicle. That weight may not safely exceed the available cargo and luggage load capacity.

The trailer’s placard refers to the Tire Information Placard attached adjacent to or near the trailer’s VIN (Certification) label at the left front of the trailer.

2.3.2 Trailers Over 10,000 Pounds GVWR

Note: These trailers are not required to have a tire information placard on the trailer and may not have one installed.

4. Determine the empty weight of your trailer by weighing the trailer using a public scale or other means. This step does not have to be repeated.
5. Locate the GVWR (Gross Vehicle Weight Rating) of the trailer on your trailer’s VIN (Certification) label.
6. Subtract the empty weight of your trailer from the GVWR stated on the VIN label. That weight is the maximum available cargo capacity of the trailer and may not be safely exceeded.



2.4 STEPS FOR DETERMINING CORRECT LOAD LIMIT – TOW VEHICLE

7. Locate the statement, “The combined weight of occupants and cargo should never exceed XXX lbs.,” on your vehicle’s placard.
8. Determine the combined weight of the driver and passengers who will be riding in your vehicle.
9. Subtract the combined weight of the driver and passengers from XXX kilograms or XXX pounds.

10. The resulting figure equals the available amount of cargo and luggage capacity. For example, if the “XXX” amount equals 1400 lbs. and there will be five 150 lb. passengers in your vehicle, the amount of available cargo and luggage capacity is 650 lbs. (1400-750 (5 x 150) = 650 lbs.).
11. Determine the combined weight of luggage and cargo being loaded on the vehicle. That weight may not safely exceed the available cargo and luggage capacity calculated in Step # 4.
12. If your vehicle will be towing a trailer, load from your trailer will be transferred to your vehicle. Consult the tow vehicle’s manual to determine how this weight transfer reduces the available cargo and luggage capacity of your vehicle.

2.5 GLOSSARY OF TIRE TERMINOLOGY

Accessory weight

The combined weight (in excess of those standard items which may be replaced) of automatic transmission, power steering, power brakes, power windows, power seats, radio and heater, to the extent that these items are available as factory-installed equipment (whether installed or not).

Bead

The part of the tire that is made of steel wires, wrapped or reinforced by ply cords and that is shaped to fit the rim.

Bead separation

This is the breakdown of the bond between components in the bead.

Bias ply tire

A pneumatic tire in which the ply cords that extend to the beads are laid at alternate angles substantially less than 90 degrees to the centerline of the tread.

Carcass

The tire structure, except tread and sidewall rubber which, when inflated, bears the load.

Chunking

The breaking away of pieces of the tread or sidewall.

Cold inflation pressure

The pressure in the tire before you drive.

Cord

The strands forming the plies in the tire.

Cord separation

The parting of cords from adjacent rubber compounds.

Cracking

Any parting within the tread, sidewall, or inner liner of the tire extending to cord material.

Section 2 - Tire Safety Information

CT

A pneumatic tire with an inverted flange tire and rim system in which the rim is designed with rim flanges pointed radially inward and the tire is designed to fit on the underside of the rim in a manner that encloses the rim flanges inside the air cavity of the tire.

Curb weight

The weight of a motor vehicle with standard equipment including the maximum capacity of fuel, oil, and coolant, and, if so equipped, air conditioning and additional weight optional engine.

Extra load tire

A tire designed to operate at higher loads and at higher inflation pressures than the corresponding standard tire.

Groove

The space between two adjacent tread ribs.

Gross Axle Weight Rating

The maximum weight that any axle can support, as published on the Certification / VIN label on the front left side of the trailer. Actual weight determined by weighing each axle on a public scale, with the trailer attached to the towing vehicle.

Gross Vehicle Weight Rating

The maximum weight of the fully loaded trailer, as published on the Certification / VIN label. Actual weight determined by weighing trailer on a public scale, without being attached to the towing vehicle.

Hitch Weight

The downward force exerted on the hitch ball by the trailer coupler.

Innerliner

The layer(s) forming the inside surface of a tubeless tire that contains the inflating medium within the tire.

Innerliner separation

The parting of the innerliner from cord material in the carcass.

Intended outboard sidewall

The sidewall that contains a white-wall, bears white lettering or bears manufacturer, brand, and/or model name molding that is higher or deeper than the same molding on the other sidewall of the tire or the outward facing sidewall of an asymmetrical tire that has a particular side that must always face outward when mounted on a vehicle.

Light truck (LT) tire

A tire designated by its manufacturer as primarily intended for use on lightweight trucks or multipurpose passenger vehicles. May be used on trailers.

Load rating

The maximum load that a tire is rated to carry for a given inflation pressure.

Maximum load rating

The load rating for a tire at the maximum permissible inflation pressure for that tire.

Maximum permissible inflation pressure

The maximum cold inflation pressure to which a tire may be inflated.

Maximum loaded vehicle weight

The sum of curb weight, accessory weight, vehicle capacity weight, and production options weight.

Measuring rim

The rim on which a tire is fitted for physical dimension requirements.

Non-pneumatic rim

A mechanical device which, when a non-pneumatic tire assembly incorporates a wheel, supports the tire, and attaches, either integrally or separably, to the wheel center member and upon which the tire is attached.

Non-pneumatic spare tire assembly

A non-pneumatic tire assembly intended for temporary use in place of one of the pneumatic tires and rims that are fitted to a passenger car in compliance with the requirements of this standard.

Non-pneumatic tire

A mechanical device which transmits, either directly or through a wheel or wheel center member, the vertical load and tractive forces from the roadway to the vehicle, generates the tractive forces that provide the directional control of the vehicle and does not rely on the containment of any gas or fluid for providing those functions.

Non-pneumatic tire assembly

A non-pneumatic tire, alone or in combination with a wheel or wheel center member, which can be mounted on a vehicle.

Normal occupant weight

This means 68 kilograms (150 lbs.) times the number of occupants specified in the second column of Table I of 49 CFR 571.110.

Occupant distribution

The distribution of occupants in a vehicle as specified in the third column of Table I of 49 CFR 571.110.

Section 2 - Tire Safety Information

Open splice

Any parting at any junction of tread, sidewall, or innerliner that extends to cord material.

Outer diameter

The overall diameter of an inflated new tire.

Overall width

The linear distance between the exteriors of the sidewalls of an inflated tire, including elevations due to labeling, decorations, or protective bands or ribs.

Pin Weight

The downward force applied to the 5th wheel or gooseneck ball, by the trailer kingpin or gooseneck coupler.

Ply

A layer of rubber-coated parallel cords.

Ply separation

A parting of rubber compound between adjacent plies.

Pneumatic tire

A mechanical device made of rubber, chemicals, fabric and steel or other materials, that, when mounted on an automotive wheel, provides the traction and contains the gas or fluid that sustains the load.

Production options weight

The combined weight of those installed regular production options weighing over 2.3 kilograms (5 lbs.) in excess of those standard items which they replace, not previously considered in curb weight or accessory weight, including heavy duty brakes, ride levelers, roof rack, heavy duty battery, and special trim.

Radial ply tire

A pneumatic tire in which the ply cords that extend to the beads are laid at substantially 90 degrees to the centerline of the tread.

Recommended inflation pressure

This is the inflation pressure provided by the vehicle manufacturer on the Tire Information label and on the Certification / VIN tag.

Reinforced tire

A tire designed to operate at higher loads and at higher inflation pressures than the corresponding standard tire.

Rim

A metal support for a tire or a tire and tube assembly upon which the tire beads are seated.

Rim diameter

This means the nominal diameter of the bead seat.

Rim size designation

This means the rim diameter and width.

Rim type designation

This means the industry of manufacturer's designation for a rim by style or code.

Rim width

This means the nominal distance between rim flanges.

Section width

The linear distance between the exteriors of the sidewalls of an inflated tire, excluding elevations due to labeling, decoration, or protective bands.

Sidewall

That portion of a tire between the tread and bead.

Sidewall separation

The parting of the rubber compound from the cord material in the sidewall.

Special Trailer (ST) Tire

The "ST" is an indication the tire is for trailer use only.

Test rim

The rim on which a tire is fitted for testing, and may be any rim listed as appropriate for use with that tire.

Tread

That portion of a tire that comes into contact with the road.

Tread rib

A tread section running circumferentially around a tire.

Tread separation

Pulling away of the tread from the tire carcass.

Treadwear indicators (TWI)

The projections within the principal grooves designed to give a visual indication of the degrees of wear of the tread.

Vehicle capacity weight

The rated cargo and luggage load plus 68 kilograms (150 lbs.) times the vehicle's designated seating capacity.

Vehicle maximum load on the tire

The load on an individual tire that is determined by distributing to each axle its share of the maximum loaded vehicle weight and dividing by two.

Vehicle normal load on the tire

The load on an individual tire that is determined by distributing to each axle its share of the curb weight, accessory weight, and normal occupant weight

Section 2 - Tire Safety Information

(distributed in accordance with Table I of CRF 49 571.110) and dividing by 2.

Weather side

The surface area of the rim not covered by the inflated tire.

Wheel center member

In the case of a non-pneumatic tire assembly incorporating a wheel, a mechanical device which attaches, either integrally or separably, to the non-pneumatic rim and provides the connection between the non-pneumatic rim and the vehicle; or, in the case of a non-pneumatic tire assembly not incorporating a wheel, a mechanical device which attaches, either integrally or separably, to the non-pneumatic tire and provides the connection between tire and the vehicle.

Wheel-holding fixture

The fixture used to hold the wheel and tire assembly securely during testing.

2.6 TIRE SAFETY - EVERYTHING RIDES ON IT

The National Traffic Safety Administration (NHTSA) has published a brochure (DOT HS 809 361) that discusses all aspects of Tire Safety, as required by CFR 575.6. This brochure is reproduced in part below. It can be obtained and downloaded from NHTSA, free of charge, from the following web site:

http://www.nhtsa.dot.gov/cars/rules/TireSafety/ridesonit/tires_index.html

Studies of tire safety show that maintaining proper tire pressure, observing tire and vehicle load limits (not carrying more weight in your vehicle than your tires or vehicle can safely handle), avoiding road hazards, and inspecting tires for cuts, slashes, and other irregularities are the most important things you can do to avoid tire failure, such as tread separation or blowout and flat tires. These actions, along with other care and maintenance activities, can also:

- Improve vehicle handling
- Help protect you and others from avoidable breakdowns and accidents
- Improve fuel economy
- Increase the life of your tires.

This booklet presents a comprehensive overview of tire safety, including information on the following topics:

- Basic tire maintenance
- Uniform Tire Quality Grading System
- Fundamental characteristics of tires
- Tire safety tips.

Use this information to make tire safety a regular part of your vehicle maintenance routine. Recognize that the time you spend is minimal compared with the inconvenience and safety consequences of a flat tire or other tire failure.

2.6.1 Safety First—Basic Tire Maintenance

Properly maintained tires improve the steering, stopping, traction, and load-carrying capability of your vehicle. Underinflated tires and overloaded vehicles are a major cause of tire failure. Therefore, as mentioned above, to avoid flat tires and other types of tire failure, you should maintain proper tire pressure, observe tire and vehicle load limits, avoid road hazards, and regularly inspect your tires.

2.6.2 Finding Your Vehicle's Recommended Tire Pressure and Load Limits

Tire information placards and vehicle certification labels contain information on tires and load limits. These labels indicate the vehicle manufacturer's information including:

- Recommended tire size
- Recommended tire inflation pressure
- Vehicle capacity weight (VCW—the maximum occupant and cargo weight a vehicle is designed to carry)
- Front and rear gross axle weight ratings (GAWR—the maximum weight the axle systems are designed to carry).

Both placards and certification labels are permanently attached to the trailer near the left front.

2.6.3 Understanding Tire Pressure and Load Limits

Tire inflation pressure is the level of air in the tire that provides it with load-carrying capacity and affects the overall performance of the vehicle. The tire inflation pressure is a number that indicates the amount of air pressure—measured in pounds per square inch (psi)—a tire requires to be properly inflated. (You will also find this number on the vehicle information placard expressed in kilopascals (kPa), which is the metric measure used internationally.)

Manufacturers of passenger vehicles and light trucks determine this number based on the vehicle's design load limit, that is, the greatest amount of weight a vehicle can safely carry and the vehicle's tire size. The proper tire pressure for your vehicle is referred to as the "recommended cold inflation pressure." (As you will read below, it is difficult to obtain the recommended tire pressure if your tires are not cold.)

Because tires are designed to be used on more than one type of vehicle, tire manufacturers list the "maximum permissible inflation pressure" on the tire sidewall. This

Section 2 - Tire Safety Information

number is the greatest amount of air pressure that should ever be put in the tire under normal driving conditions.

2.6.4 Checking Tire Pressure

It is important to check your vehicle's tire pressure at least once a month for the following reasons:

- Most tires may naturally lose air over time.
- Tires can lose air suddenly if you drive over a pothole or other object or if you strike the curb when parking.
- With radial tires, it is usually not possible to determine underinflation by visual inspection.

For convenience, purchase a tire pressure gauge to keep in your vehicle. Gauges can be purchased at tire dealerships, auto supply stores, and other retail outlets. The recommended tire inflation pressure that vehicle manufacturers provide reflects the proper psi when a tire is cold. The term cold does not relate to the outside temperature. Rather, a cold tire is one that has not been driven on for at least three hours. When you drive, your tires get warmer, causing the air pressure within them to increase. Therefore, to get an accurate tire pressure reading, you must measure tire pressure when the tires are cold or compensate for the extra pressure in warm tires.

2.6.5 Steps for Maintaining Proper Tire Pressure

- Step 1: Locate the recommended tire pressure on the vehicle's tire information placard, certification label, or in the owner's manual.
- Step 2: Record the tire pressure of all tires.
- Step 3: If the tire pressure is too high in any of the tires, slowly release air by gently pressing on the tire valve stem with the edge of your tire gauge until you get to the correct pressure.
- Step 4: If the tire pressure is too low, note the difference between the measured tire pressure and the correct tire pressure. These "missing" pounds of pressure are what you will need to add.
- Step 5: At a service station, add the missing pounds of air pressure to each tire that is underinflated.
- Step 6: Check all the tires to make sure they have the same air pressure (except in cases in which the front and rear tires are supposed to have different amounts of pressure).

If you have been driving your vehicle and think that a tire is underinflated, fill it to the recommended cold inflation pressure indicated on your vehicle's tire information placard or certification label. While your tire may still be slightly underinflated due to the extra pounds of pressure in the warm tire, it is safer to drive with air pressure that is slightly lower than the vehicle

manufacturer's recommended cold inflation pressure than to drive with a significantly underinflated tire. Since this is a temporary fix, don't forget to recheck and adjust the tire's pressure when you can obtain a cold reading.

2.6.6 Tire Size

To maintain tire safety, purchase new tires that are the same size as the vehicle's original tires or another size recommended by the manufacturer. Look at the tire information placard, the owner's manual, or the sidewall of the tire you are replacing to find this information. If you have any doubt about the correct size to choose, consult with the tire dealer.

2.6.7 Tire Tread

The tire tread provides the gripping action and traction that prevent your vehicle from slipping or sliding, especially when the road is wet or icy. In general, tires are not safe and should be replaced when the tread is worn down to 1/16 of an inch. Tires have built-in treadwear indicators that let you know when it is time to replace your tires. These indicators are raised sections spaced intermittently in the bottom of the tread grooves. When they appear "even" with the outside of the tread, it is time to replace your tires. Another method for checking tread depth is to place a penny in the tread with Lincoln's head upside down and facing you. If you can see the top of Lincoln's head, you are ready for new tires.

2.6.8 Tire Balance and Wheel Alignment

To avoid vibration or shaking of the vehicle when a tire rotates, the tire must be properly balanced. This balance is achieved by positioning weights on the wheel to counterbalance heavy spots on the wheel-and-tire assembly. A wheel alignment adjusts the angles of the wheels so that they are positioned correctly relative to the vehicle's frame. This adjustment maximizes the life of your tires. These adjustments require special equipment and should be performed by a qualified technician.

2.6.9 Tire Repair

If a tire loses all or most of its air pressure, it should be removed from the wheel for a complete inspection for possible internal damage. Tires that are run even for short distances while flat are often damaged beyond repair. Remember these important points on tire repair:

- Most punctures and nail holes in the tread area up to 1/4" can be repaired.
- Only trained personnel, using industry approved methods and materials, should repair a tire.
- Tires with sidewall punctures or a tread depth of less than 1/16" should be replaced and not repaired.

The proper repair of a punctured tire requires a plug for the hole and a patch for the area inside the tire that surrounds the puncture hole.

Section 2 - Tire Safety Information

2.6.10 Tire Fundamentals

Federal law requires tire manufacturers to place standardized information on the sidewall of all tires. This information identifies and describes the fundamental characteristics of the tire and also provides a tire identification number for safety standard certification and in case of a recall.

2.6.10.a Information on Passenger Vehicle Tires

Please refer to the diagram below.

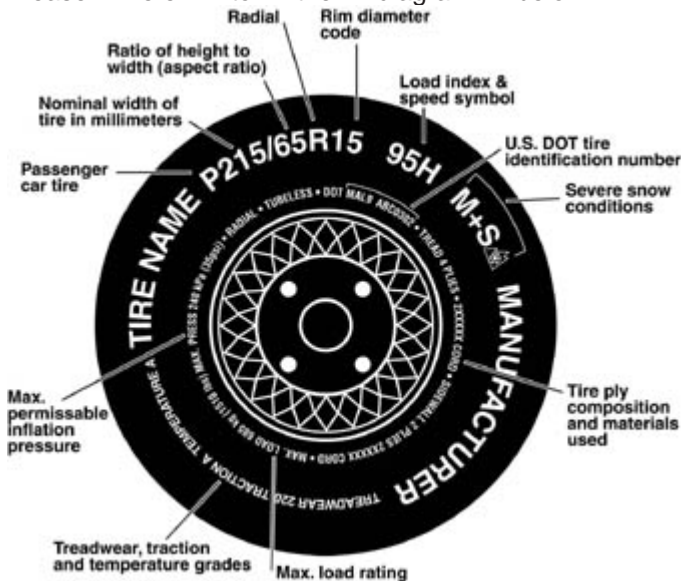

P

The "P" indicates the tire is for passenger vehicles.

Next Number

This three-digit number gives the width in millimeters of the tire from sidewall edge to sidewall edge. In general, the larger the number, the wider the tire.

Next Number

This two-digit number, known as the aspect ratio, gives the tire's ratio of height to width. Numbers of 70 or lower indicate a short sidewall for improved steering response and better overall handling on dry pavement.

R

The "R" stands for radial. Radial ply construction of tires has been the industry standard for the past 20 years.

Next Number

This two-digit number is the wheel or rim diameter in inches. If you change your wheel size, you will have to purchase new tires to match the new wheel diameter.

Next Number

This two- or three-digit number is the tire's load index. It is a measurement of how much weight each tire can support. You may find this information in your owner's

manual. If not, contact a local tire dealer. Note: You may not find this information on all tires because it is not required by law.

M+S

The "M+S" or "M/S" indicates that the tire has some mud and snow capability. Most radial tires have these markings; hence, they have some mud and snow capability.

Speed Rating

The speed rating denotes the speed at which a tire is designed to be driven for extended periods of time. Note: You may not find this information on all tires because it is not required by law.

U.S. DOT Tire Identification Number

This begins with the letters "DOT" and indicates that the tire meets all federal standards. The next two numbers or letters are the plant code where it was manufactured, and the last four numbers represent the week and year the tire was built. For example, the numbers 3197 means the 31st week of 1997. The other numbers are marketing codes used at the manufacturer's discretion. This information is used to contact consumers if a tire defect requires a recall.

Tire Ply Composition and Materials Used

The number of plies indicates the number of layers of rubber-coated fabric in the tire. In general, the greater the number of plies, the more weight a tire can support. Tire manufacturers also must indicate the materials in the tire, which include steel, nylon, polyester, and others.

Maximum Load Rating

This number indicates the maximum load in kilograms and pounds that can be carried by the tire.

Maximum Permissible Inflation Pressure

This number is the greatest amount of air pressure that should ever be put in the tire under normal driving conditions.

2.6.10.b UTQGS Information

Treadwear Number

This number indicates the tire's wear rate. The higher the treadwear number is, the longer it should take for the tread to wear down. For example, a tire graded 400 should last twice as long as a tire graded 200.

Traction Number

This letter indicates a tire's ability to stop on wet pavement. A higher graded tire should allow you to stop your car on wet roads in a shorter distance than a tire with a lower grade. Traction is graded from highest to lowest as "AA", "A", "B", and "C".

Temperature Letter

Section 2 - Tire Safety Information

This letter indicates a tire's resistance to heat. The temperature grade is for a tire that is inflated properly and not overloaded. Excessive speed, underinflation or excessive loading, either separately or in combination, can cause heat build-up and possible tire failure. From highest to lowest, a tire's resistance to heat is graded as "A", "B", or "C".

2.6.10.c Information on Light Truck (LT) Tires

Please refer to the following diagram.



Tires for light trucks have other markings besides those found on the sidewalls of passenger tires.

LT

The "LT" indicates the tire is for light trucks or trailers.

Max. Load Dual kg (lbs) at kPa (psi) Cold

This information indicates the maximum load and tire pressure when the tire is used as a dual, that is, when four tires are put on each rear axle (a total of six or more tires on the vehicle).

Max. Load Single kg (lbs) at kPa (psi) Cold

This information indicates the maximum load and tire pressure when the tire is used as a single.

Load Rating

This information identifies the tire's load-carrying capabilities and its inflation limits.

2.6.10.d Information on Special Trailer (ST) Tires

Please refer to the following diagram.

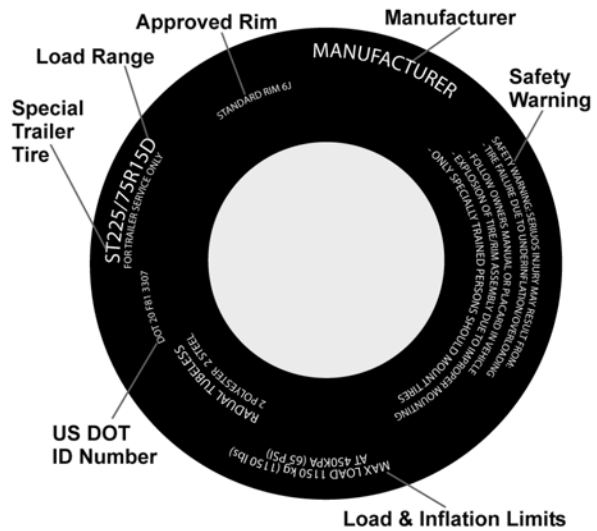

Tires designated for trailers only have other markings besides those found on the sidewalls of passenger tires.

ST

An "ST" is an indication the tire is for trailer use only. "ST" tires are designed for carrying heavy loads at lower speeds.

The Tire and Rim Association Standard indicates that for operation at speeds up to 65 mph, no change in maximum cold tire inflation pressure or load is required. For speeds between 66-75 mph, increase the maximum cold tire inflation pressure 10 psi.

Max. Load Dual kg (lbs) at kPa (psi) Cold

This information indicates the maximum load and tire pressure when the tire is used as a dual, that is, when four tires are put on each rear axle (a total of six or more tires on the vehicle).

Max. Load Single kg (lbs) at kPa (psi) Cold

This information indicates the maximum load and tire pressure when the tire is used as a single.

Load Range

This information identifies the tire's load-carrying capabilities and its inflation limits.

2.6.11 Tire Safety Tips

Preventing Tire Damage

- Slow down if you have to go over a pothole or other object in the road.
- Do not run over curbs or other foreign objects in the roadway, and try not to strike the curb when parking.

Tire Safety Checklist

Section 2 - Tire Safety Information

- Check tire pressure regularly (at least once a month), including the spare.
- Inspect tires for uneven wear patterns on the tread, cracks, foreign objects, or other signs of wear or trauma.
- Remove bits of glass and foreign objects wedged in the tread.
- Make sure your tire valves have valve caps.
- Check tire pressure before going on a long trip.
- Do not overload your vehicle. Check the tire information placard or owner's manual for the maximum recommended load for the vehicle.

Section 3 - COUPLING TO THE TOW VEHICLE

This manual provides instructions for the operation and care of Haulmark trailers. The instructions in the manual must be followed to ensure safety of persons, and cargo, and satisfactory life of the trailer. Safety precautions to protect against injury or property damage must be followed at all times.

This section of the manual is organized into the following subsections:

- Using an adequate tow vehicle and hitch
- Coupling the trailer to the tow vehicle
- Loading the trailer
- Checking the trailer for safety before each tow
- Breaking in a new trailer
- Synchronizing the brakes
- Uncoupling the trailer

Trailer Accessories

Haulmark offers trailers with a wide range of accessories. Instructions for safe use of these accessories are located in separate instruction manuals, some of which are provided by the accessory manufacturer.

Section 7 of this manual contains instructions regarding the use of some accessory items, such as:

- Gasoline or diesel generators
- Accessory Battery
- “Shore Power” connections to provide power by “plugging the trailer in” to an external source of electrical power
- LP (Liquid Petroleum Gas) facilities for heating or other uses
- Electric-powered hydraulic landing gear
- Vending or Accessory Doors

Your Haulmark trailer has been built using parts from various component manufacturers. Where this manual indicates that you should read another manual, and you do not have that manual, call Haulmark Industries, Inc. at 1-800-348-7530 for assistance.

3.1 USE AN ADEQUATE TOW VEHICLE AND HITCH

If the tow vehicle or hitch is not properly selected and matched to the Gross Vehicle Weight Rating (GVWR) of your trailer, you can cause an accident that could lead to death or serious injury. Tow vehicle and hitch manufacturers are the appropriate source of competent advice.

If you already have a tow vehicle, know your vehicle tow rating and make certain the trailer’s rated capacity is less than or equal to the tow vehicle’s rated towing capacity.

⚠ DANGER

Use of an under-rated hitch, ball or tow vehicle can result in loss of control leading to death or serious injury.

Make certain your hitch and tow vehicle are rated for your trailer.

3.1.1 Trailer Information

The “Trailer Certification (VIN) Tag” (1) location figure shows the location of the Certification / Vehicle Identification Number (VIN) tag on your trailer. See figure 3-1 or 3-2.

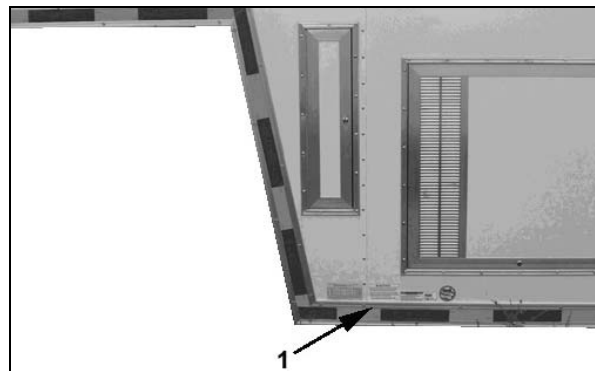

*Gooseneck Certification (VIN) Tag
Location - Figure 3-1*

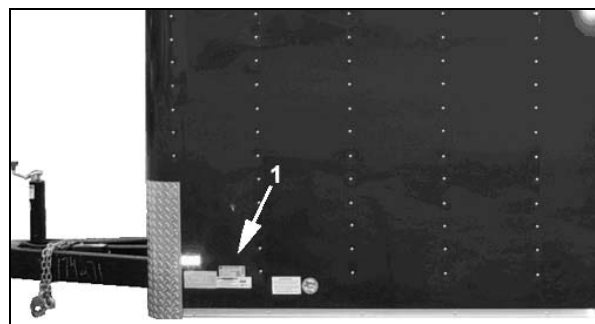

*Bumper Pull Certification (VIN) Tag
Location - Figure 3-2*

Section 3 - Coupling To The Tow Vehicle

The trailer Certification (VIN) tag contains the following critical safety information for the use of your trailer:

MANUFACTURER: Name of trailer manufacturer

DATE OF MANUFACTURE: Month and year the trailer was manufactured.

GAWR: The Gross Axle Weight Rating is the maximum gross weight that an axle can support. It is the lowest of axle, wheel, or tire rating. Sometimes the tire or wheel rating is lower than the axle manufacturers rating, and will then determine GAWR.

GVWR: The Gross Vehicle Weight Rating is the maximum allowable gross weight of the trailer and its contents. The gross weight of the trailer includes the weight of the trailer and all of the items within it (such as cargo, water, food and other supplies). GVWR is sometimes referred to as GTW (Gross Trailer Weight), or MGTW (Maximum Gross Trailer Weight). GVWR, GTW and MGTW are all the same rating.

The sum total of the GAWR for all trailer axles may be less than the GVWR for the trailer, because some of the trailer load is carried by the tow vehicle, rather than by the trailer axle(s). **The total weight of the cargo and trailer must not exceed the GVWR, and the load on an axle must not exceed its GAWR.**

PSIC: The “pounds per square inch-cold” is the tire pressure (Kilopascals / Pounds per Square Inch) measured when Cold.

VIN: The Vehicle Identification Number.

VEHICLE TYPE: Trailer plus the model number of the trailer.

Certification Statement: “This trailer meets all the Federal Motor Vehicle Safety Standards in effect on the date of manufacture shown above.”

There are two additional weights that are not provided on the Certification (VIN) tag that are important, and that should be put somewhere on the trailer. These are the “empty weight” and “maximum cargo weight”.

The “empty weight” is sometimes put on the Manufacturer’s Certificate of Origin (Title) but may not be accurate for your particular trailer, due to accessories, optional equipment, etc. The best way to determine empty weight is to weigh the entire trailer on a “Certified” scale at a truck stop. This requires detaching the trailer and leaving the entire trailer on the scale. Furthermore, it is desirable to weigh the tongue weight. This can be done by re-attaching the trailer to the tow vehicle, after getting the empty weight, and then just

weighing the trailer axles(s). Subtracting the axle weight from the empty weight gives you the tongue weight.

Knowing the empty weight now allows you to calculate the “maximum cargo weight”. Simply subtract the empty weight from the GVWR shown on the Certification / VIN tag.

While you’re at the scale it is also a good idea to weigh the towing vehicle, with driver, in the typical towing scenario. This will provide you with the total “combination vehicle weight”, which can then be compared to the allowable Gross Combined Weight Rating (GCWR) provided by the tow vehicle manufacturer, as discussed below.

3.1.2 Tow Vehicle

When equipping a new vehicle or an older vehicle to tow your trailer, ask the vehicle dealer for advice on how to outfit the towing vehicle. Discuss the following information and equipment with the vehicle dealer.

Overall Carrying and Towing Capacity of Vehicle: Vehicle manufacturers will provide you with the maximum towing capacities of their various models, as well as the GCWR. No amount of reinforcement will give a 100 horsepower, 2,500 pound truck the towing capacity that a 300 horsepower, 5,000 pound truck has.

Towing Hitch: The towing hitch attached to your tow vehicle must have a capacity equal to or greater than the load rating of the trailer you intend to tow. The hitch capacity must also be matched to the tow vehicle capacity.

Suspension System: A tow vehicle equipped with a factory installed “Towing Package” likely comes equipped with heavy duty springs, heavy duty tires and other suspension components which are able to serve the size and weight of the trailer that the vehicle is rated to tow. However, the addition of additional equipment may further improve the tow vehicle performance. These may include adjustable air shocks, helper springs, etc.

Brake Controller: The brake controller is part of the tow vehicle and is essential in the operation of the electric brakes on the trailer. If your trailer has electric brakes it requires a brake controller be installed at the driver’s position. The brake controller is not the same as the safety breakaway brake system that is installed on the trailer.

Side View Mirrors: The size of the trailer that is being towed and your state law regulations determine the size of the mirrors. However, some states prohibit extended mirrors on a tow vehicle, except while a trailer is actually being towed. In this situation, detachable extended mirrors are necessary. Check with your dealer or the appropriate state agency for mirror requirements.

Section 3 - Coupling To The Tow Vehicle

Heavy Duty Flasher: A Heavy Duty Flasher is an electrical component that may be required when your trailer turn signal lights are attached to the tow vehicle flasher circuit.

Electrical Connector: An Electrical Connector connects the light and brake systems on the trailer to the light and brake controls on the towing vehicle.

Heavy Duty Engine Oil Cooling System: The tow vehicle engine works harder when a trailer is being towed. Depending on the size of the trailer, you may need to install a separate engine oil cooler. Inadequate cooling may result in sudden engine failure. Ask the tow vehicle dealer if it is necessary to install a heavy duty cooling system.

Automatic Transmission Oil Cooler: The automatic transmission of a towing vehicle handles more power when a trailer is being towed. Inadequate cooling will shorten transmission life, and may result in sudden transmission failure. Ask the tow vehicle dealer if it is necessary to install a separate oil cooler for the automatic transmission.

Fire Extinguisher: It is sensible to have a fire extinguisher in the tow vehicle.

Emergency Flares and Emergency Triangle Reflectors: It is wise to carry these warning devices even if you are not towing a trailer. It is particularly important to have these when towing a trailer because the hazard flashers of your towing vehicle will not operate for as long a period of time when the battery is running both the trailer lights and tow vehicle lights.

3.2 COUPLING AND UNCOUPLING THE TRAILER

A secure coupling (or fastening) of the trailer to the tow vehicle is essential. A loss of coupling may result in death or serious injury. Therefore, you must understand and follow all of the instructions for coupling.

The following parts are involved in making a secure coupling between the trailer and tow vehicle:

Coupling: That part of the trailer connecting mechanism by which the connection is actually made to the trailer hitch. This does not include any structural member, extension of the trailer frame, or brake controller. (per SAE J684)

Hitch: That part of the connecting mechanism including the ball support platform and ball and those components that extend and are attached to the towing vehicle,

including bumpers intended to serve as hitches. (per SAE J684)

Safety chains: Chains are permanently attached to the trailer such that if the coupler connection comes loose, the safety chains can keep the trailer attached to the tow vehicle. With properly rigged safety chains, it is possible to keep the tongue of the trailer from digging into the road pavement, even if the coupler-to-hitch connection comes apart.

Trailer lighting (and braking) connector: A device that connects electrical power from the tow vehicle to the trailer. Electricity is used to turn on brake lights, running lights, and turn signals as required. In addition, if your trailer has a separate braking system, the electrical connector will also supply power to the trailer brakes from the tow vehicle.

Breakaway switch: If the trailer becomes de-coupled from the towing vehicle, the breakaway switch lanyard, attached independently to the tow vehicle hitch, will pull a pin in the emergency electrical breakaway switch on the trailer. The breakaway switch is activated by a separate battery supply in the trailer such as to energize the trailer brakes independently of the towing vehicle. It is important to check the state of charge of the emergency breakaway battery before each trip. Simply pull the pin out of the switch by hand and then try to pull the trailer. If you feel a significant drag force the brakes are activated. Be sure to re-insert the pin in the breakaway switch. Also be sure to allow enough slack in the breakaway brake lanyard such that the switch will only activate (pin pulls out) if the coupler connection comes loose.

Jack: A device on the trailer that is used to raise and lower the trailer tongue. On larger trailers the jack is sometimes called the "landing gear."

Section 3 - Coupling To The Tow Vehicle

⚠ WARNING

An improperly coupled trailer can result in death or serious injury.

Do not move the trailer until:

- The coupler is secured and locked;
 - The safety chains are secured to the tow vehicle; and
 - The trailer jacks are fully retracted.
- Do not tow the trailer on the road until:
- The trailer brakes are checked;
 - The breakaway switch is connected to the tow vehicle;
 - The load is secured to the trailer; and
 - The trailer lights are connected and checked.

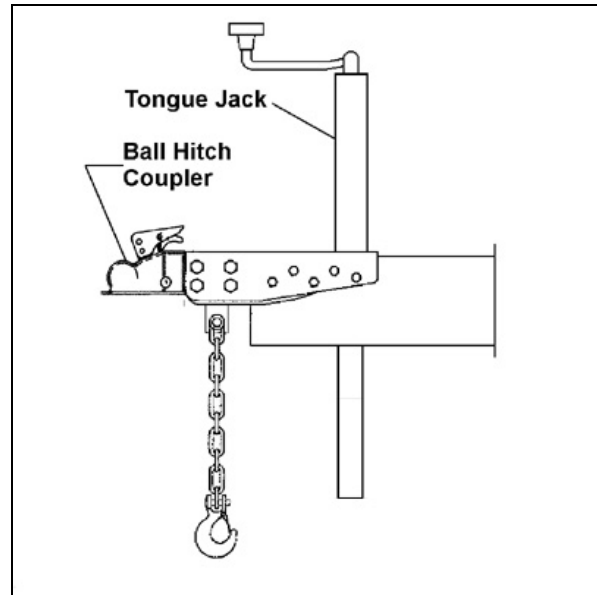

Trailer with Ball Hitch Coupler - Figure

3-3

Couplers

Haulmark trailers are produced with a variety of coupler devices. One of the sections below will pertain to your trailer.

- Bumper pull (Ball Hitch) Coupler
- Gooseneck Ball Hitch Coupler
- Gooseneck Fifth Wheel Coupler

If you need information or assistance with your coupler, call Haulmark Industries, Inc. at 800-348-7530 or your dealer.

3.2.1 Trailer with Ball Hitch Coupler

A ball hitch coupler connects to a ball that is located on or under the rear bumper of the tow vehicle. This system of coupling a trailer to a tow vehicle is sometimes referred to as “bumper pull.”

A ball hitch trailer may be fitted with a tongue jack that can raise and lower the coupler. The tongue jack is mounted to the A-frame (front, or tongue) part of the trailer. By rotating the jack handle clockwise, the jack will extend and raise the tongue of the trailer. Figure 3-3 shows a trailer with a ball hitch coupler.

Be sure the Ball Hitch coupler is suitable for the size and weight of the trailer. The load rating of the coupler and the necessary ball size are listed on the trailer tongue. You must provide a hitch and ball for your tow vehicle, where the load rating of the hitch and ball is equal to or greater than that of your trailer. Also, the ball size must be the same as the coupler size. If the hitch ball is too small, too large, is underrated, is loose or is worn, the trailer can come loose from the tow vehicle, and may cause death or serious injury.

THE TOW VEHICLE, HITCH AND BALL MUST HAVE A RATED TOWING CAPACITY EQUAL TO OR GREATER THAN THE TRAILER Gross Vehicle Weight Rating (GVWR).

IT IS ESSENTIAL THAT THE HITCH BALL BE OF THE SAME SIZE AS THE COUPLER.

IF THE HITCH BALL IS TOO SMALL, IS UNDERRATED, IS LOOSE OR IS WORN, THE TRAILER CAN COME LOOSE FROM THE TOW VEHICLE, RESULTING IN DEATH OR SERIOUS INJURY.

The ball size and load rating (capacity) are marked on the ball; hitch capacity is marked on the hitch.

3.2.1.a Before Coupling the Trailer to the Tow Vehicle

- Be sure the size and rating of hitch ball match the size and rating of the coupler. Hitch balls and couplers are marked with their size and rating.

Section 3 - Coupling To The Tow Vehicle

⚠ WARNING

Coupler-to-hitch mismatch can result in uncoupling, leading to death or serious injury.

Make sure the hitch and ball are rated for the trailer coupling.

Make sure the hitch [ball size] matches the coupler.

- Wipe the hitch ball clean and inspect it visually and by feel for flat spots, cracks and pits.

⚠ WARNING

A worn, cracked or corroded hitch ball can fail while towing, and may result in death or serious injury.

Check the hitch ball for wear, corrosion and cracks before coupling the trailer.

Replace worn, corroded or cracked hitch ball before coupling the trailer.

- Rock the ball to make sure it is tight to the hitch, and visually check that the hitch ball nut is solid against the lock washer and hitch frame.
- Wipe the inside and outside of the coupler clean and inspect it visually for cracks and deformations; feel the inside of the coupler for worn spots and pits.
- Be sure the coupler is tight to the tongue of the trailer. All coupler fasteners must be visibly solid against the trailer frame.

⚠ WARNING

A loose hitch ball nut can result in uncoupling, leading to death or serious injury.

Make sure the hitch ball is tight to the hitch before coupling the trailer.

3.2.1.b Prepare the Coupler and Hitch

- Lubricate the hitch ball and the inside of the coupler with a thin layer of automotive bearing grease. Using the jack, raise the coupler above the ball height.
- Open the coupler locking mechanism. Ball couplers have a locking mechanism with an external moving piece (ball clamp) and an outside handle or latch. See figure 3-4.

- In the open or released position, the coupler is able to drop fully onto the hitch ball.
- Slowly back up the tow vehicle so that the hitch ball is near or aligned under the coupler, if the trailer jack has raised the coupler.

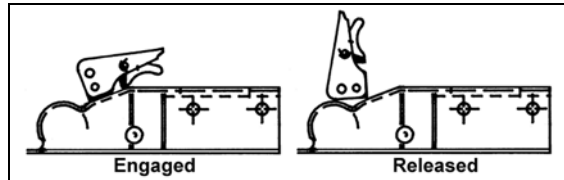

Ball Hitch Coupler Mechanism - Figure

3-4

3.2.1.c Couple the Trailer to the Tow Vehicle

- Using the jack, lower the trailer tongue until the coupler fully engages the hitch ball. If the coupler does not line up with the hitch ball, adjust the position of the tow vehicle.
- Engage the coupler locking mechanism. In the engaged position, the locking mechanism securely holds the coupler to the hitch ball.
- Insert a pin or lock through the hole in the locking mechanism.
- Be sure the coupler is all the way on the hitch ball and the locking mechanism is engaged. A properly engaged locking mechanism will allow the coupler to raise the rear of the tow vehicle. Using the trailer jack, test to see that you can raise the rear of the tow vehicle by 1 inch, after the coupler is locked to the hitch.

NOTICE

The tongue jack can be damaged by overloading. Do not use the tongue jack to raise the tow vehicle more than 1 inch.

If the coupler cannot be secured to the hitch ball, do not tow the trailer. Call Haulmark Industries, Inc. at 800-348-7530 or your dealer for assistance.

- Lower the trailer so that its entire tongue weight is held by the hitch, and continue retracting the jack to its fully retracted position.

Section 3 - Coupling To The Tow Vehicle

3.2.1.d Rig the Safety Chains

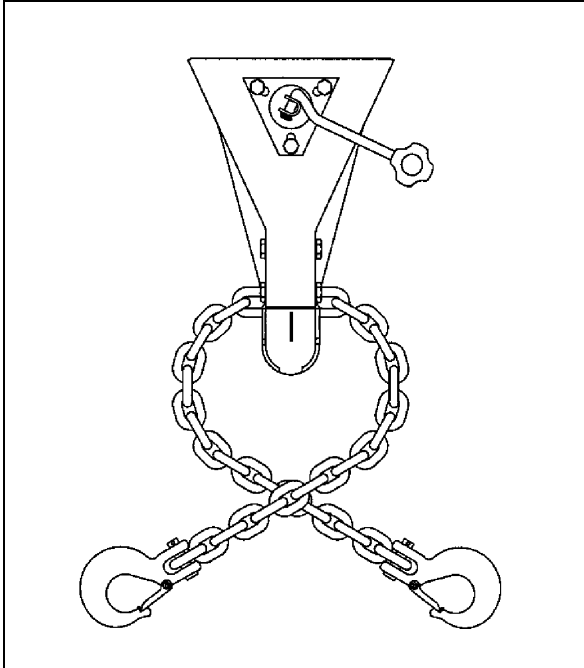

Safety Chain Arrangement - Figure 3-5

- Visually inspect the safety chains and hooks for wear or damage. Replace worn or damaged safety chains and hooks before towing.
- Rig the safety chains so that they:
 - Cris-cross underneath the coupler so if the trailer uncouples, the safety chains can hold the tongue up above the road. See figure 3-5.
 - Loop around a frame member of the tow vehicle or to holes provided in the hitch system (but, do **not** attach them to an interchangeable part of the hitch assembly)
 - Attach hooks up from underneath the hole (do not just drop into hole); and
 - Provide enough slack to permit tight turns, but not be close to the road surface to drag.

⚠ WARNING

Incorrect rigging of the safety chains can result in loss of control of the trailer and tow vehicle, leading to death or serious injury, if the trailer uncouples from the tow vehicle.

Chains must:

- Fasten to frame of tow vehicle, not to hitch or ball.
- Cross underneath hitch and coupler with minimum slack to permit turning and to hold tongue up, if the trailer comes loose.

3.2.1.e Attach and Test the Breakaway Brake System

If the coupler or hitch fails, a properly connected and working breakaway brake system will apply electric brakes on the trailer. The safety chains will keep the tow vehicle attached and as the brakes are applied at the trailer's axles, the trailer/tow vehicle combination will come to a controlled stop.

The breakaway brake system includes a controller, battery, and a switch with a pullpin, and lanyard. Read and follow the instructions here as well as the instructions that have been prepared by the breakaway brake manufacturer.

The breakaway brake system may be fitted with a "charging" capability that draws power from the tow vehicle. If the electrical system on your tow vehicle does not provide power to the breakaway brake battery, you must periodically charge the battery to keep the breakaway brake system in working order.

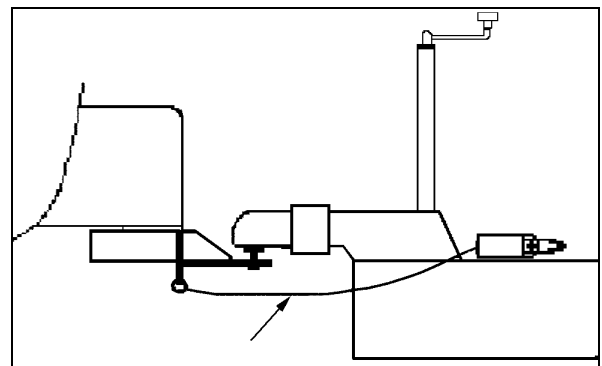

Breakaway Brake Connection - figure

3-6

Section 3 - Coupling To The Tow Vehicle

- Visually inspect the breakaway system for broken or missing parts. Repair or replace worn, damaged or missing parts before towing trailer.
- Connect the pullpin lanyard to the tow vehicle so that the pullpin will be pulled out before all of the slack in the safety chains is taken up (see Breakaway Brake Connection figure 3-6). Do **not** connect the pullpin lanyard to a safety chain or to the hitch ball or hitch ball assembly. This would keep the breakaway brake system from operating when it is needed.
- To test the breakaway brake battery, remove the pullpin from the switch and attempt to pull the trailer forward. You should feel the trailer resisting being towed, but the wheels will not necessarily be locked. If the brakes do not function, do not tow the trailer until brakes, or battery, are repaired.
- Immediately replace the pullpin. The breakaway brake system battery discharges rapidly when the pullpin is removed.

WARNING

An ineffective breakaway brake system can result in a runaway trailer, leading to death or serious injury if the coupler or ball hitch fails.

Test the function of the breakaway brake system before towing the trailer. Do not tow the trailer if the breakaway brake system is not working; have it serviced or repaired.

Connect the breakaway lanyard to the tow vehicle -

NOT to the safety chain; and

NOT to the hitch, ball or support.

Do **not** tow the trailer with the breakaway brake system ON because the brakes will overheat which can result in permanent brake failure.

WARNING

Failure to replace the pullpin can result in ineffective brakes, leading to loss of control, serious injury or death.

If you do not use your trailer for three or more months, or during winter months:

- Store the battery indoors; and
- Charge the battery every three months.

Replace the breakaway brake battery according to the intervals specified by the battery manufacturer.

3.2.1.f **Connect the Electrical Cables**

Connect the trailer lights to the tow vehicle's electrical system using the electrical connectors.

- Check all lights for proper operation.
 - Clearance and Running Lights (Turn on tow vehicle headlights).
 - Brake Lights (Step on tow vehicle brake pedal).
 - Turn Signals (Operate tow vehicle directional signal lever).
- Check electric brakes for proper operation using brake controller mounted in the cab.

If your trailer has electric brakes, your tow vehicle will have an electric brake controller that sends power to the trailer brakes. Before towing the trailer on the road, you must operate the brake controller while trying to pull the trailer in order to confirm that the electric brakes operate. While towing the trailer at less than 5 m.p.h., manually operate the electric brake controller in the tow vehicle cab. You should feel the operation of the trailer brakes.

WARNING

Failure to connect the tow vehicle lighting and braking to the trailer will result in inoperable lights and brakes, and can lead to collision.

Check that all the trailer lights and brakes work before each tow.

3.2.1.g **Uncoupling the Ball Hitch Trailer**

Follow these steps to uncouple your ball hitch trailer from the tow vehicle:

- Block trailer tires to prevent the trailer from rolling, before jacking the trailer up.
- Disconnect the electrical connector.
- Disconnect the breakaway brake switch lanyard.
- Disconnect the safety chains from the tow vehicle.
- Unlock the coupler and open it.
- Before extending jack, make certain the ground surface below the jack pad will support the tongue load.
- Rotate the jack handle (or crank) clockwise. This will slowly extend the jack and transfer the weight of the trailer tongue to the jack.

Section 3 - Coupling To The Tow Vehicle

3.2.2 Trailer with Gooseneck Coupler and Drop-Leg Jack

A gooseneck coupler on the trailer connects to a gooseneck ball that you must have installed in the bed of the tow vehicle. This system of coupling a trailer to a tow vehicle permits the tow vehicle to turn to sharper angles than are permitted by a bumper hitch system. A gooseneck coupler consists of a tube in an inverted “U” shape and a gooseneck ball receiver. Figure 3-7 shows a trailer with a gooseneck coupler.

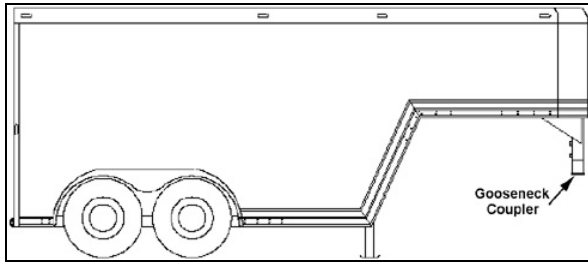

Trailer with Gooseneck Coupler - Figure 3-7

We have utilized a Gooseneck ball receiver that is suitable for the size and weight of the trailer. The load rating of the coupler and the necessary ball size are listed on the gooseneck.

You must provide a gooseneck ball and support structure that is marked with a rating that meets or exceeds the GVW Rating of your trailer **and** matches the size of the gooseneck ball receiver. If the gooseneck ball is too small, is underrated, is loose or is worn, the trailer can come loose from the tow vehicle, and may lead to death or serious injury.

THE TOW VEHICLE, SUPPORT STRUCTURE AND GOOSENECK BALL MUST HAVE A RATED TOWING CAPACITY EQUAL TO OR GREATER THAN THE TRAILER Gross Vehicle Weight Rating (GVWR).

IT IS ESSENTIAL THAT THE GOOSENECK BALL BE OF THE SAME SIZE AS THE GOOSENECK BALL RECEIVER.

IF THE GOOSENECK BALL IS TOO SMALL, IS UNDERRATED, IS LOOSE OR IS WORN, THE TRAILER CAN COME LOOSE FROM THE TOW VEHICLE, RESULTING IN DEATH OR SERIOUS INJURY.

The gooseneck ball size and load rating (capacity) are marked on the ball; hitch capacity is marked on the hitch.

⚠ WARNING

Coupler-to-hitch mismatch can result in uncoupling, leading to death or serious injury.

Make sure the hitch and ball are rated for the trailer coupling.

Make sure the hitch [ball size] matches the coupler.

3.2.2.a Adjust Gooseneck Hitch Height

It is your responsibility to have the height of the coupler adjusted to match the height of the gooseneck ball in your tow vehicle. Proper coupler height adjustment is required to provide clearance between the bottom of the trailer and sides of the tow vehicle bed, to obtain level running of the trailer and to permit equal weight distribution on the axles. Your Haulmark dealer is able to perform the coupler height adjustment to match the trailer to your towing vehicle.

- Loosen the jam nut and set screw (A) on the coupler. See figure 3-8.
- Remove retaining pin (B) and load bearing pin (C).
- Extend or retract the coupler as needed up to a maximum of 8 inches from the fully retracted position.
- Fully insert load bearing pin (B) through one set of holes in coupler and outer tube. **NEVER use the set screw or any other device as a replacement for the load bearing pin (B).**
- Install retaining pin (C) on load bearing pin (B).
- Tighten setscrew (A) to 75-100 lb/ft of torque.
- Tighten jam nuts to 80-90 lb/ft of torque.
- Check tightness after 50 miles of towing.

Section 3 - Coupling To The Tow Vehicle

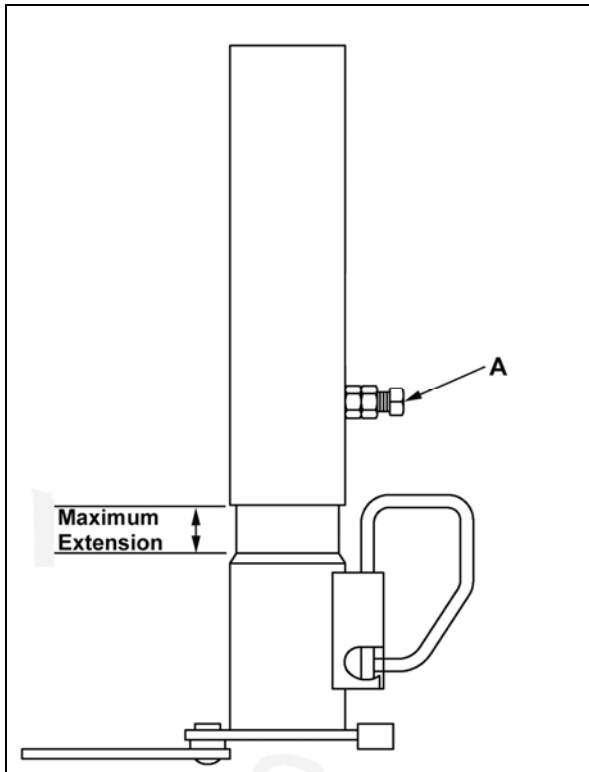

Coupler Height Adjustment - Figure 3-8

⚠ WARNING

Improper gooseneck height adjustment can result in overloaded tires, blowout and loss of control, leading to death or serious injury.

Adjust the gooseneck receiver so that the trailer runs level.

3.2.2.b Drop-Leg Jack(s)

A trailer having a gooseneck hitch will have one or two drop leg jacks for raising and lowering the gooseneck ball receiver. Because several drop leg jack mechanisms are available, the general instructions below may vary slightly from the jack manufacturer's instructions. If the trailer jack on your trailer does not resemble the jack shown in the figure 3-9, follow the jack instructions provided by the jack manufacturer.

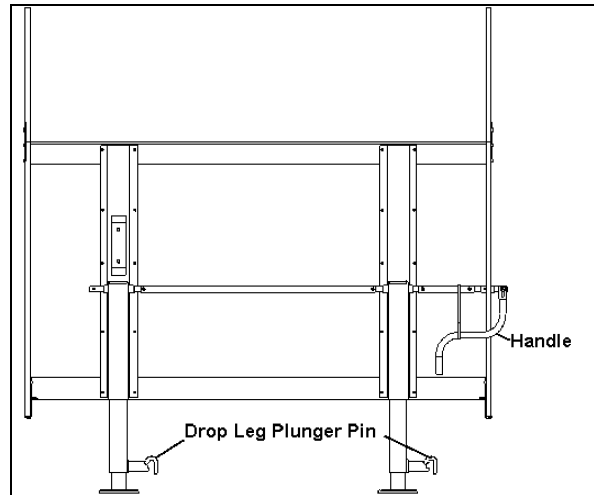

Drop-Leg Jack Arrangement - Figure 3-9

3.2.2.c Before Coupling the Trailer to the Tow Vehicle

- Be sure the size and rating of the gooseneck ball match the size and rating of the receiver. Gooseneck balls and receivers are marked with their size and ratings.
- Wipe the gooseneck ball clean and inspect it visually and by feel for flat spots, cracks and pits.

⚠ WARNING

A worn, cracked or corroded gooseneck ball can fail while towing, and may result in death or serious injury.

Check the gooseneck ball for wear, corrosion and cracks before coupling the trailer.

Replace worn, corroded or cracked gooseneck ball before coupling the trailer.

- Rock the ball to make sure it is tight to the ball support, and visually check that the gooseneck ball nut is solid against the lock washer and ball support frame.

⚠ WARNING

A loose gooseneck ball can result in uncoupling, leading to death or serious injury.

Make sure the gooseneck ball nut is tight before coupling the trailer.

- Wipe the inside and outside of the receiver clean and inspect it visually for cracks; and feel the inside of the receiver for worn spots and pits. If any of

Section 3 - Coupling To The Tow Vehicle

these conditions exist, have the receiver replaced before coupling the trailer.

- Lubricate the inside of the gooseneck ball receiver with automotive bearing grease.
- Be sure the receiver is tight to the trailer. All receiver fasteners must be visibly solid against the trailer frame.
- Release the jack handle or crank from its holder (see “Drop Leg Jack” figure 3-9).
- Rotate the handle/crank clockwise to raise the bottom surface of the gooseneck to be above the top of the gooseneck ball.
- If the tow vehicle has a tailgate, lower it.

3.2.2.d Prepare the Ball Receiver and Gooseneck Ball

- Release the lock plate on the gooseneck ball receiver. With the spring-loaded lock plate locking pin in the OPEN position, rotate the lock plate to a position that allows the gooseneck ball to enter the receiver (see “Gooseneck Ball Receiver and Height Adjustment” figure 3-8).
- Slowly back up the tow vehicle so that the gooseneck ball is aligned under the gooseneck ball receiver.

WARNING

No one must be under the trailer or coupler during the coupling.

Death or serious injury can occur if the trailer drops.

3.2.2.e Couple the Trailer to the Tow Vehicle

- Rotate the jack handle counter-clockwise. This will retract the jack causing the gooseneck ball receiver to drop down so it can fully engage the gooseneck ball and transfer the weight of the trailer tongue to the towing vehicle hitch. If the receiver does not line up with the ball, raise the receiver again and adjust the position of the tow vehicle. Then lower the receiver over the ball. When the drop leg base is no longer resting on the ground, the towing vehicle hitch is holding all of the weight of the trailer tongue.
- Close the lock plate on the gooseneck ball receiver.
- Move the spring-loaded lock plate locking pin to the CLOSED position. Be sure the locking pin is holding the lock plate.
- Be sure the receiver is all the way on the gooseneck ball and the lock plate is engaged. A properly engaged locking mechanism will allow the coupler to raise the rear of the tow vehicle. Using the trailer

jack, test to see that you can raise the rear of the tow vehicle by 1 inch.

NOTICE

The drop leg jack can be damaged by overloading. Do not use the drop leg jack to raise the tow vehicle more than 1 inch.

If the gooseneck ball cannot be secured to the receiver, do not tow the trailer. Call Haulmark Industries, Inc. at 800-348-7530 or your dealer for assistance.

- After testing to see that the receiver is properly secured and locked to the ball, retract the jack to its fully retracted position.
- Return the drop legs to their upper positions. The drop legs are held in the lowered position with a plunger pin. Rotating the plunger pin while pulling it outward will cause it to come out of engagement with the drop leg and the leg will rapidly rise. See figure 3-10.
- If the tow vehicle is equipped with a tailgate, raise it.
- Pick up the trailer wheel blocks.

CAUTION

The drop legs are heavily spring loaded in the lowered position. They will rapidly return to the upper position when released and can inflict serious bruises, scrapes or pinching.

Keep your feet, shins and hands well clear of the drop legs and drop leg bases when releasing the drop legs.

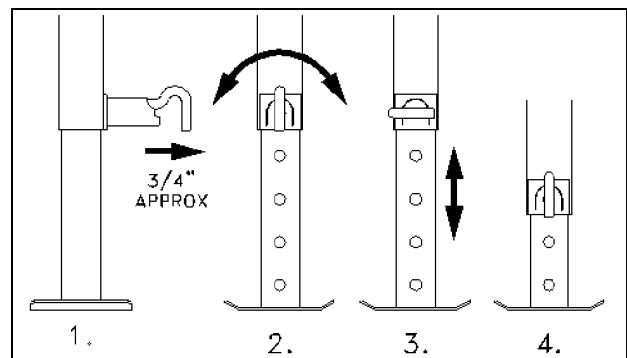

Drop Leg Jack Mechanism - Figure 3-10

3.2.2.f Rig the Safety Chains

- Visually inspect the safety chains and hooks for wear or damage. Replace worn or damaged safety chains and hooks before towing.

Section 3 - Coupling To The Tow Vehicle

- Rig the safety chains so that they attach to the “safety chain receivers” on the tow vehicle. If you are not certain of the hitch provisions for receiving safety chains, contact the hitch manufacturer or installer. Do NOT attach the safety chains to the gooseneck ball or its support; and
- Rig the safety chains so they have sufficient slack to permit turning, but not too much slack – the safety chains must keep the gooseneck on the tow vehicle bed if the trailer uncouples. See figure 3-11.

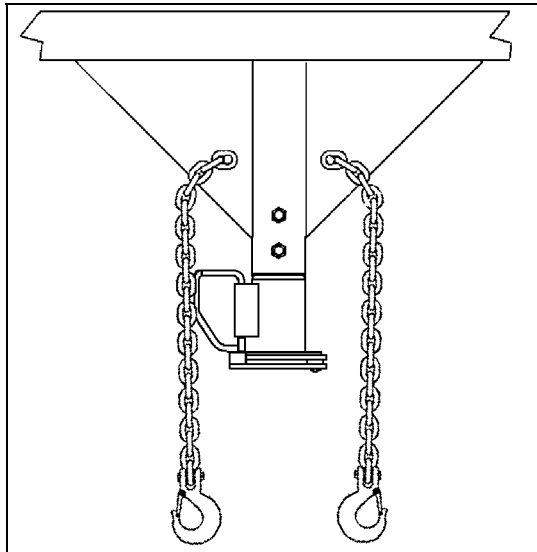

Safety Chain Arrangement - Figure 3-11

⚠ WARNING

Improper rigging of the safety chains can result in loss of control of the trailer and tow vehicle, leading to death or serious injury, if the trailer uncouples from the tow vehicle.

- **Fasten chains to safety chain receivers on the hitch, not to ball.**
- **Have sufficient slack to permit turning and to keep gooseneck on bed of tow vehicle, if the trailer comes loose.**

3.2.2.g **Attach and Test the Breakaway Brake System**

If the coupler or hitch fails, a properly connected and working breakaway brake system will apply electric brakes on the trailer. The safety chains will keep the tow vehicle attached and as the brakes are applied at the trailer’s axles, the trailer/tow vehicle combination will come to a controlled stop. See figure 3-12.

The breakaway brake system includes a breakaway brake controller, battery, and a switch with a pullpin, and lanyard. Read and follow the instructions here as

well as the instructions that have been prepared by the breakaway brake controller manufacturer.

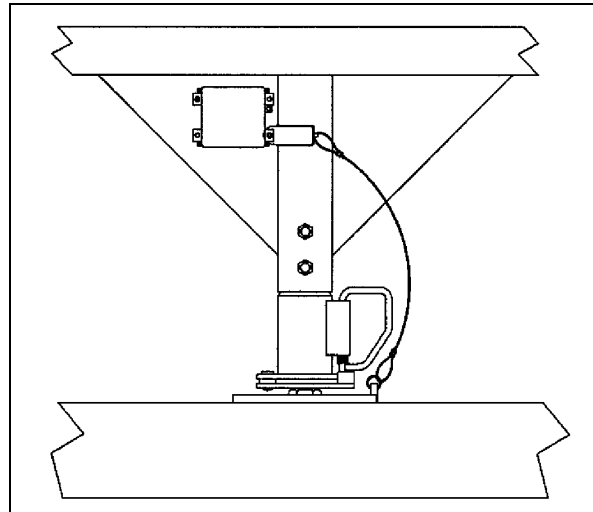

Breakaway Brake Connection - Figure 3-12

The breakaway brake system may be fitted with a charging facility that draws power from the tow vehicle. If the electrical system on your tow vehicle does not provide power to the breakaway brake battery you must periodically charge the battery on the trailer to keep the breakaway brake system in working order.

- Visually inspect the breakaway brake system for broken parts.
- Connect the pullpin lanyard to the tow vehicle so that the pullpin will be pulled out before all of the slack in the safety chains is taken up (see “Breakaway Brake Connection” figure 3-12). Do **not** connect the pullpin lanyard to a safety chain, safety chain receiver, or to the gooseneck ball or its support. This would keep the breakaway brake system from operating when it is needed. Contact the hitch manufacturer or installer if you are not certain of the hitch provisions for the breakaway brake connection.
- To test the breakaway brake battery, pull out the pullpin from the switch and attempt to pull the trailer forward. You should feel the trailer resisting being towed, but the wheels will not necessarily be locked. If the brakes do not function, do not tow the trailer until brakes, or battery, are repaired.
- Immediately replace the pullpin. The breakaway brake system battery discharges rapidly when the pullpin is removed.

Section 3 - Coupling To The Tow Vehicle

WARNING

An ineffective or inoperative breakaway brake system can result in a runaway trailer leading to death or serious injury if the coupler or hitch fails.

Connect the breakaway lanyard to the tow vehicle; and NOT to the safety chain, safety chain receiver, gooseneck ball or gooseneck ball support.

Test the function of the breakaway brake system before towing the trailer. Do not tow the trailer if the breakaway brake system is not working. Have it serviced or repaired.

Do **not** tow the trailer with the breakaway brake system ON because the brakes will overheat which can result in permanent brake failure.

WARNING

Failure to replace the pullpin can result in ineffective brakes, leading to loss of control, serious injury or death.

If you do not use your trailer for three or more months, or during winter months:

- Store the battery indoors; and
- Charge the battery every three months.

Replace the breakaway brake battery according to the intervals specified by the battery manufacturer.

3.2.2.h **Connect the Electrical Cables**

Connect the trailer lights to the tow vehicle's electrical system using the electrical connectors.

- Check all lights for proper operation:
 - Clearance and Running Lights (Turn on tow vehicle headlights).
 - Brake Lights (Step on tow vehicle brake pedal).
 - Turn Signals (Operate tow vehicle directional signal lever).
- Check electric brakes for proper operation using the controller mounted in the cab.

If your trailer has electric brakes, your tow vehicle will have an electric brake controller that sends power to the trailer brakes. Before towing the trailer on the road, you

must operate the brake controller while trying to pull the trailer in order to confirm that the electric brakes operate. While towing the trailer at less than 5 m.p.h., manually operate the electric brake controller in the tow vehicle cab. You should feel the operation of the trailer brakes.

WARNING

Failure to connect the tow vehicle lighting and braking to the trailer will result in inoperable lights and brakes, and can lead to collision.

Check that all the trailer lights and brakes work before each tow.

3.2.2.i **Uncoupling the Gooseneck Trailer with Drop-Leg Jack**

Follow these steps to uncouple your gooseneck hitch trailer from the tow vehicle:

- Block trailer tires to prevent the trailer from rolling, before jacking the trailer up
- Disconnect the electrical connector.
- Disconnect the breakaway brake switch lanyard.
- Disconnect the safety chains from the tow vehicle.
- If the tow vehicle has a tailgate, lower it.
- Move the spring-loaded gooseneck receiver lock plate locking pin to the OPEN position (see “Gooseneck Ball Receiver and Height Adjustment” figure).
- Rotate the lock plate to a position that permits the gooseneck ball to exit the receiver.
- Before releasing dropleg jack, make certain ground surface below jack base will support the trailer tongue load.
- Rotate the drop leg plunger pin handle so that the plunger pin is released from the drop leg (see “Releasing Drop Leg Mechanism” figure).
- Push down on the drop leg base with your foot to place a drop leg to the desired lowered position.
- Rotate the plunger pin handle so that the plunger pin is attempting to engage the drop leg (see “Drop Leg Jack Mechanism” figure)
- Slowly raise your foot, permitting the drop leg to rise. The plunger pin will engage a hole in the drop leg.

Section 3 - Coupling To The Tow Vehicle

CAUTION

The drop legs are heavily spring loaded in the lowered position. They will rapidly return to the upper position when released and can inflict serious bruises, scrapes or pinching.

Keep your feet, shins and hands well clear of the drop legs and drop leg bases when releasing the drop legs.

- Be sure the plunger pin is fully engaged. Push it in by hand if necessary. The bent part of the plunger pin handle must be touching the plunger pin housing.
- If your trailer has two drop leg jacks, lower them both to the same level, following the above instructions.

NOTICE

If the drop legs are not set at the same level, one of the drop leg jacks can be overloaded and can be damaged.

- Release the handle (or crank) from its holder and engage it with the jack shaft (see “Drop Leg Jack Mechanism” figure 3-10).
- Rotate the handle (or crank) from its hold and engage it with the jack shaft.
- Rotate the handle (or crank) clockwise to slowly extend the jack and transfer the weight of the trailer tongue to the jack.
- On two speed jacks, pushing the handle shaft toward the gearbox can perform rapid extension. This shifts the gearbox into a high speed mode.
- When the drop leg base contacts the ground, shift the gearbox into low speed mode by pulling out on the handle shaft until it locks into low gear.

NOTICE

Do not use high speed to lift the trailer, the drop leg jack mechanism can be damaged.

High speed is used only to rapidly move the drop leg base into contact with the ground.

Continue to extend the jack(s), making sure that the ground is providing stable and level support for the trailer.

After the jack(s) are extended and the gooseneck ball receiver is well clear of the gooseneck ball, to permit

driving the tow vehicle away, disengage the handle from its shaft and return to its holder.

3.2.3 Trailer with Fifth Wheel Coupler and Drop-Leg Jack

A fifth wheel coupler on the trailer connects to a kingpin that is installed on the tow vehicle. A fifth wheel coupler on the tow vehicle connects to a kingpin that is installed on the trailer. See figures 3-13 and 3-14.

A fifth wheel coupler includes a flat load-bearing plate with a slot, and a mechanism inside the slot that “grips” the kingpin.

Haulmark has selected a fifth wheel coupler that is suitable for the size and weight of the trailer. You must provide a kingpin and kingpin plate that match the fifth wheel, and that is rated for the Gross Vehicle Weight Rating (GVWR) of your trailer.

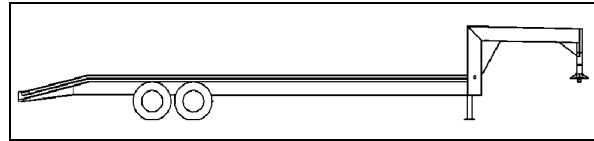

*Trailer with Fifth Wheel Coupler -
Figure 3-13*

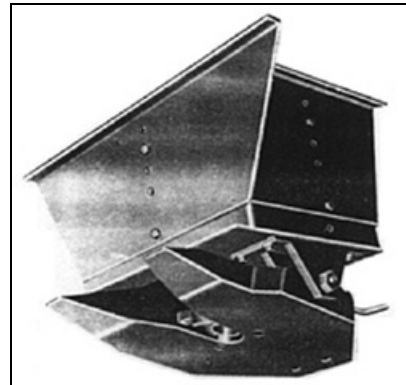

Fifth Wheel Coupler - Figure 3-14

3.2.3.a Before Coupling the Trailer to the Tow Vehicle

- Be sure the size and rating of the fifth wheel and kingpin match.
- Wipe the kingpin clean and inspect it visually and by feel for flat spots, cracks and pits. Check the condition of the kingpin mounting in the bed of the tow vehicle.

Section 3 - Coupling To The Tow Vehicle

⚠ WARNING

A worn, bent, cracked or corroded kingpin can fail while towing, and may result in death or serious

Check the kingpin and kingpin plate for wear, bending, cracks or corrosion before coupling.

Replace worn, bent, cracked or corroded kingpin before coupling the trailer.

- Be sure the fifth wheel mechanism operates freely.
- Lubricate the fifth wheel plate surface with a light coat of Lithium-base, waterproof grease.
- Be sure the fifth wheel and kingpin fasteners are tight and any welds are solid.

⚠ WARNING

A loose fifth wheel or kingpin can result in uncoupling, leading to death or serious injury.

Make sure the fifth wheel and kingpin are tight before coupling the trailer.

- Be sure the brake line, electrical line, and any other lines are clear of the coupling area.

3.2.3.b Adjust Hitch Height

It is your responsibility to have the height of the king pin or fifth wheel adjusted to match the height of the fifth wheel or king pin in your tow vehicle. Proper height adjustment is required to provide clearance between the bottom of the trailer and sides of the tow vehicle bed, to obtain level running of the trailer and to permit equal weight distribution on the axles. Your Haulmark dealer is able to perform the coupler height adjustment to match the trailer to your towing vehicle.

- Loosen the jam nuts and set screws (A) on the rear side. See figure 3-15.
- Extend or retract the king pin or fifth wheel as needed, but do not exceed 8 inches maximum extension.
- Tighten setscrews (A) to 75-100 lb ft of torque.
- Tighten jam nuts to 80-90 lb/ft of torque.
- Check tightness after 50 miles of towing.

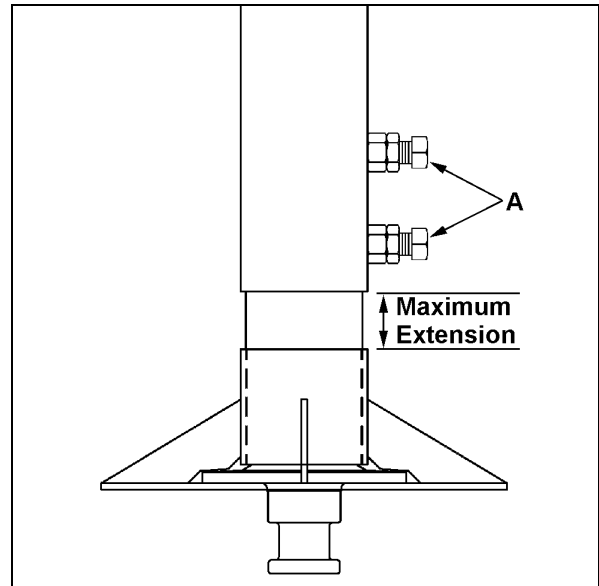

King Pin Height Adjustment - Figure 3-15

3.2.3.c Prepare the Fifth Wheel Coupler

- Be sure the locks are open (see “Fifth Wheel Checks” figure 3-16).
- If the tow vehicle is equipped with a tailgate, lower it.
- Block the trailer wheels, front and rear.
- Make certain that trailer fifth wheel plate is slightly above the kingpin plate on the tow vehicle.

3.2.3.d Couple the Trailer to the Tow Vehicle

⚠ WARNING

Incorrect rigging of the safety chains can result in loss of control of the trailer and tow vehicle, leading to death or serious injury, if the trailer uncouples from the tow vehicle.

Chains must:

- **Fasten to frame of tow vehicle, not to hitch or ball.**
 - **Cross underneath hitch and coupler with minimum slack to permit turning and to hold tongue up, if the trailer comes loose.**
- Back tow vehicle up close to the trailer, centering the kingpin in the slot of the fifth wheel.
 - **STOP** before engaging the coupling.

Section 3 - Coupling To The Tow Vehicle

⚠ WARNING

No one must be under the trailer or coupler during the coupling.

Death or serious injury can occur if the trailer drops.

- Adjust the height of the trailer, using the jack, so that the fifth wheel plate just touches the kingpin plate.
- Slowly back up the tow vehicle, keeping the kingpin centered in the slot of the fifth wheel. Continue backing up until the fifth wheel locks firmly on the kingpin.
- Visually check to confirm that the fifth wheel locks are properly locked onto the kingpin by performing the three checks illustrated in the “Fifth Wheel Checks” figure 3-16.
- Attempt to pull forward as an initial test of the closing of the fifth wheel locks.

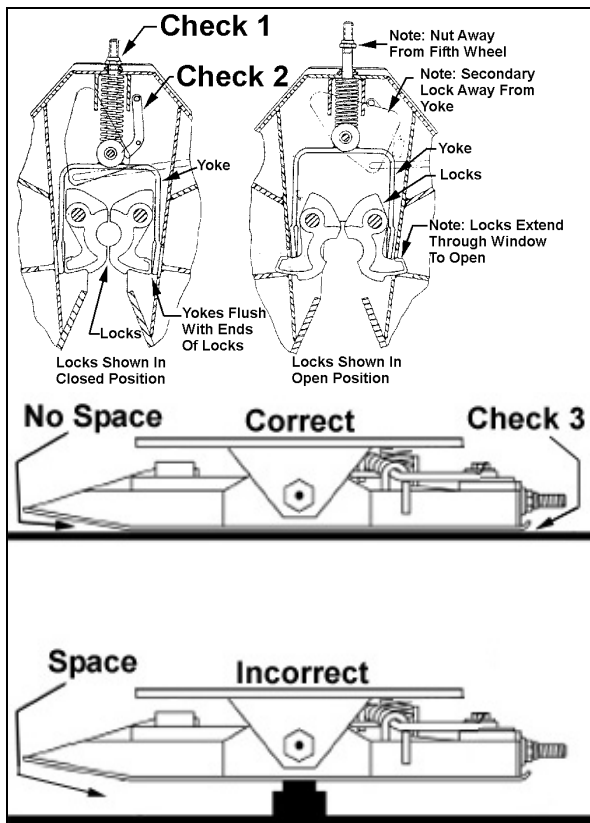

Fifth Wheel Checks - Figure 3-16

- Check 1 – The adjustment nut must be seated against the fifth wheel.
- Check 2 – The secondary lock must be behind the yoke.
- Check 3 – The fifth wheel must be in contact with the kingpin plate, with **no space**.

⚠ WARNING

An improperly coupled fifth wheel can come loose, resulting in death or serious injury.

Do not tow the trailer until all of the visual checks are met.

- **Adjustment nut against fifth wheel.**
- **Secondary lock behind yoke.**
- **Fifth wheel against kingpin plate.**

Raise The Drop-Leg Jack

A trailer having a fifth wheel coupler will be outfitted with one or two drop leg jacks for raising and lowering the fifth wheel coupler. Because we use several drop leg jack mechanisms, the general instructions below may vary slightly from the jack manufacturer’s instructions. If the trailer jack on your trailer does not resemble the jack shown in the figures, follow the jack instructions provided by the jack manufacturer.

- Rotate the jack handle counter-clockwise. This will slowly retract the jack and transfer the weight of the trailer tongue to the towing vehicle. When the drop leg base is no longer resting on the ground, the towing vehicle hitch is holding all of the weight of the trailer tongue. Continue retracting the jack to its fully retracted position.
- Return the drop legs to their upper position. The drop legs are held in the lowered position with a plunger pin. Rotating the plunger pin while pulling it outward about $\frac{3}{4}$ inch will cause it to come out of the engagement with the drop leg and the leg will rapidly raise. See figure 3-17.
- Raise the tailgate.
- Pick up the trailer wheel blocks.

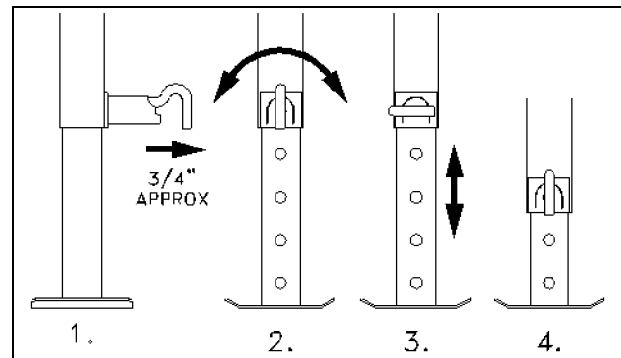

Drop Leg Jack Mechanism - Figure 3-17

Section 3 - Coupling To The Tow Vehicle

⚠ CAUTION

The drop legs are heavily spring loaded in the lowered position. They will rapidly return to the upper position when released and can inflict serious bruises, scrapes or pinching.

Keep your feet, shins and hands well clear of the drop legs and drop leg bases when releasing the drop legs.

3.2.3.e Attach and Test the Breakaway Brake System

If the coupler fails, a properly connected and working breakaway brake system will apply electric brakes on the trailer. See figure 3-18.

The breakaway brake system includes a breakaway brake controller, battery and a switch with a pullpin and lanyard. Read and follow the instructions here as well as the instructions that have been prepared by the breakaway brake controller manufacturer.

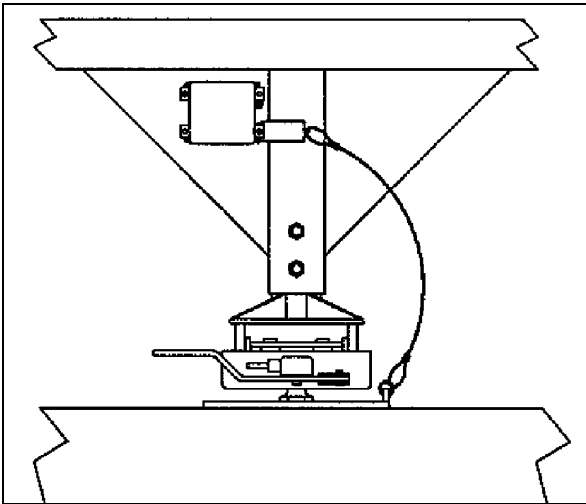

Breakaway Brake Connection - Figure 3-18

The breakaway brake system may be fitted with a charging facility that draws power from the tow vehicle. If the electrical system on your tow vehicle does not provide power to the breakaway brake battery, you must periodically charge the battery to keep the breakaway brake system in working order.

- Visually inspect the breakaway brake system for broken parts.
- Connect the pullpin lanyard to the tow vehicle (see "Breakaway Brake Connection" figure 3-18). Do **not** connect to kingpin or its support.

- To test the breakaway battery remove the pullpin from the switch and attempt to pull the trailer forward. You should feel the trailer resisting being towed, but the wheels will not necessarily be locked. If the brakes do not function, do not tow the trailer until brakes, or battery, are repaired.
- Immediately replace the pullpin. The breakaway brake system battery discharges rapidly when the pullpin is removed.

⚠ WARNING

An ineffective breakaway brake system can result in a runaway trailer, if the fifth wheel hitch fails, leading to death or serious injury.

Test the function of the breakaway brake system before towing the trailer. Do not tow the trailer if the breakaway brake system is not working; have it serviced or repaired.

Connect the breakaway lanyard to the tow vehicle-

NOT to the kingpin or its support.

Do **not** tow the trailer with the breakaway brake system ON because the brake will overheat which can result in permanent brake failure.

⚠ WARNING

Failure to replace the pullpin can result in ineffective brakes, leading to loss of control, serious injury or death.

If you do not use your trailer for three or more months, or during winter months:

- Store the battery indoors; and
- Charge the battery every three months.

Replace the breakaway brake battery at intervals recommended by the battery manufacturer

3.2.3.f Connect the Electrical Cables

- Connect the trailer lights to the tow vehicle's electrical system using the electrical connectors. Check all lights for proper operation:
 - Clearance and Running Lights (Turn on tow vehicle headlights).
 - Brake Lights (Step on Tow vehicle brake pedal).
 - Turn Signals (Operate tow vehicle directional signal lever).

Section 3 - Coupling To The Tow Vehicle

Check brakes for proper operation: While towing the trailer at less than 5 m.p.h., manually operate the electric brake controller in the tow vehicle cab. You should feel the operation of the trailer brakes.

WARNING

Failure to connect the tow vehicle lighting and braking to the trailer will result in inoperable lights and brakes, and can lead to collision.

Check that all the trailer lights and brakes work before each tow.

3.2.3.g Rig the Safety Chains

- Visually inspect the safety chains and hooks for wear or damage. Replace worn or damaged safety chains and hooks before towing.
- Rig the safety chains so that they attach to the “safety chain receivers” on the tow vehicle. If you are not certain of the hitch provisions for receiving safety chains, contact the hitch manufacturer or installer. Do NOT attach the safety chains to the fifth wheel or its support; and
- Rig the safety chains so they have sufficient slack to permit turning, but not too much slack – the safety chains must keep the gooseneck on the tow vehicle bed if the trailer uncouples.

3.2.3.h Uncoupling the Fifth Wheel Trailer

Follow these steps to uncouple your fifth wheel hitch trailer from your tow vehicle.

- Block trailer tires to prevent the trailer from rolling before jacking the trailer up.
- Disconnect the electrical connector.
- Disconnect the breakaway brake switch lanyard.
- If the tow vehicle has a tailgate, lower it.
- Make certain that ground surface below jack base will support trailer tongue load.
- Rotate the drop leg plunger pin handle so that the plunger pin is released from the drop leg. See figure 3-19.
- Push down on the drop leg base with your foot to place a drop leg to the desired lowered position.

CAUTION

The drop legs are heavily spring loaded in the lowered position. They will rapidly return to the upper position when released and can inflict serious bruises, scrapes or pinching.

Keep your feet, shins and hands well clear of the drop legs and drop leg bases when releasing the drop legs.

- Rotate the plunger pin handle so that the plunger pin is attempting to engage the drop leg. See figure 3-17.
- Slowly raise your foot, permitting the drop leg to rise. The plunger pin will engage a hole in the drop leg.
- Be sure the plunger pin is fully engaged. Push it in by hand if necessary. The bent part of the plunger pin handle must be touching the plunger pin housing.
- If your trailer has two drop leg jacks, lower them both to the same level, following the preceding instructions.

NOTICE

If the drop legs are not set at the same level, one of the drop leg jacks can be overloaded and can be damaged.

- Release the handle (or crank) from its holder and engage it with the jack shaft.
- Rotate the handle (or crank) clockwise to slowly extend the jack and transfer the weight of the trailer tongue to the jack.
- On two speed jacks, pushing the handle shaft toward the gearbox can perform rapid extension. This shifts the gearbox into a high speed mode.
- When the drop leg base contacts the ground, shift the gearbox into low speed mode by pulling out on the handle shaft until it locks into low gear.

NOTICE

Do not use high speed to lift the trailer, the drop leg jack mechanism can be damaged.

High speed is used only to rapidly move the drop leg base into contact with the ground.

- Continue to extend the jack(s), making sure that the ground is providing stable and level support for the trailer.

Section 3 - Coupling To The Tow Vehicle

- Turn the crank two or three turns to take some of the weight of the coupling. Do **not** raise the fifth wheel off the kingpin plate.
- After the jack(s) are extended enough to permit driving the tow vehicle away, disengage the jack handle from its shaft and return it to its holder. Do **NOT** drive the tow vehicle yet!

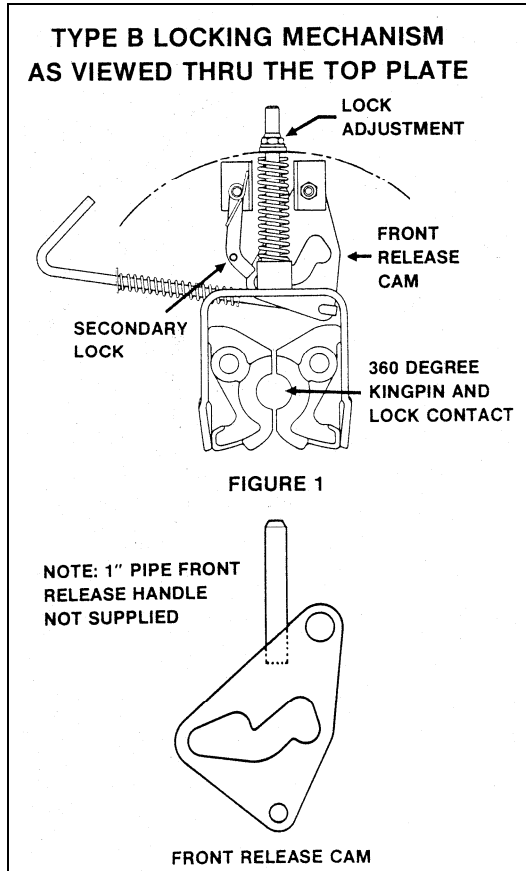

Opening Fifth Wheel Locks - Figure 3-19

- Open the fifth wheel locks by:
 - Pulling the release handle, or
 - Using a separate pipe release handle to engage the solid stud on the secondary lock. See figure 3-19.
- Slowly drive the tow vehicle away from the trailer.
- Raise the tow vehicle tailgate.

Section 4 - LOADING THE TRAILER

Improper trailer loading causes many accidents and deaths. To safely load a trailer, you must consider:

- Overall load weight;
- Load weight distribution;
- Proper tongue weight; and
- Securing the load properly.

To determine that you have loaded the trailer within its rating, you must consider the total weight of the trailer and its contents. The trailer axles carry all of the total weight of the trailer and its contents (Gross Vehicle Weight, or “GVW”).

It is essential for safe towing that the trailer axles be capable of carrying the loaded trailer weight, otherwise the trailer can develop an undesirable sway at towing speeds, or the rear of the towing vehicle can be overloaded. Read the “Tongue Weight” section that follows.

The load distribution must be such that no component part of the trailer is loaded beyond its rating. This means that you must consider the rating of the tires, wheels and axles. For tandem and triple axle trailers, you must make sure that the front-to-rear load distribution does not result in overloading any axle.

Towing stability also depends on keeping the center of gravity as low as possible. Load heavy items on the floor and over the axles. When loading additional items, be sure to maintain even side-to-side weight distribution and proper tongue weight. The total weight of the trailer and its contents must never exceed the total weight rating of the trailer (Gross Vehicle Weight Rating, or “GVWR”).

WARNING

An overloaded trailer can result in failure or in loss of control of the trailer, leading to death or serious injury.

Never load a trailer so that the weight on any tire exceeds its rating.

Never exceed the trailer Gross Vehicle Weight Rating (GVWR).

Never exceed an axle Gross Axle Weight Rating (GAWR).

Tongue Weight

It is critical to have a portion of the trailer load carried by the hitch mechanism. That is, the trailer tongue must exert a downward force on the hitch. This is necessary for two reasons. First, the proper amount of tongue weight is necessary for the tow vehicle to be able to maintain control of the tow vehicle/trailer system.

If, for example, the tongue exerts an upward pull on the hitch, instead of pushing down on it (because the trailer is overloaded behind its axle(s)), the rear wheel of the tow vehicle can lose traction or grip and cause loss of control. Also, even if there is some weight on the tongue, but not enough weight on the tongue, the trailer can become unstable at high speeds. Remember, the faster you go, the more likely the trailer is to sway.

If, on the other hand, there is too much tongue weight, the tow vehicle is prone to jack-knife. Furthermore, the front wheels of the tow vehicle can be too lightly loaded and cause loss of steering control and traction, if the front wheels are driving.

In addition to tow vehicle control, tongue weight is necessary to insure that the trailer axle(s) do not exceed their Gross Axle Weight Rating (GAWR).

In the following table, the second column notes the rule of thumb percentage of total weight of the trailer plus its cargo (Gross Vehicle Weight, or “GVW”) that should appear on the tongue of the trailer. For example, a trailer with a gooseneck hitch, with a loaded weight of 12,000 pounds, should have 20-25% of 12,000 pounds on the tongue. That is, the example trailer would have 2,400 to 3,000 pounds on its tongue. This 2,400 to 3,000 pounds does not add to the GVWR of the trailer.

Approximate Tongue Weight as a Percentage of Loaded Trailer Weight	
Type of Hitch	Percentage
Ball Hitch (or Bumper Hitch)	15%
Gooseneck Hitch	20–25%
Fifth Wheel Hitch	

Section 4 - Loading The Trailer

WARNING

An improperly distributed load can result in loss of control of the trailer, and can lead to death or serious injury.

Proper tongue weight is essential for stable trailer handling.

Distribute the load front to rear to provide proper tongue weight.

Distribute the load evenly, right and left, to avoid tire overload.

Keeping the center of gravity low and centered is essential to minimize the risk of tip-over.

4.1 CHECKING TONGUE WEIGHT

To check the tongue weight, the tow vehicle and trailer must be on level ground, as they will be when the trailer is being towed.

For lighter trailers the recommended method of checking tongue weight is to use an accessory called a “tongue weight scale.” The tongue weight scales may be available from your Haulmark dealer. (The 2000 lb. capacity model is most commonly useful.)

WARNING

An unrestrained trailer can fall off its support, resulting in serious injury or death.

Block trailer wheels, front and rear, before checking tongue weight.

For most trailers it is easier to go to a truck stop where there is a “certified” scale. Pull the trailer onto the scale and decouple it from the tow vehicle, leaving just the trailer on the scale. Get a “ticket”, which lists the total trailer weight. Re-connect the trailer to your tow vehicle and the drive the tow vehicle wheels off the scale, just leaving the trailer axles on the scale. Get a second “ticket”, which lists the trailer’s axle weight. Simple subtract the axle weight from the total weight to determine the hitch weight.

It is also desirable, while you are at the scale, to weigh the entire combination vehicle. This result should be less than the Gross Combined Weight Rating (GCWR) for your towing vehicle. Some scales allow you to get individual axle weights also. If this is possible, get the tow vehicles front and rear axle weights to make sure

they are in the same proportion as the tow vehicle alone, and that the rear axle is not overloaded.

You are responsible to secure your cargo in such a way that it does not shift within the trailer, while the trailer is being towed. The “ride” inside a trailer can be very bumpy and rough.

WARNING

A shifting load can result in failure, or to loss of control of the trailer, and can lead to death or serious injury.

You must tie down all loads with proper sized fasteners, ropes, straps, etc. to prevent the load from shifting while trailering.

4.2 LOADING CARGO

Couple the trailer to the tow vehicle before loading. The tongue of a bumper pull trailer can rise during loading, before the cargo is properly distributed.

Depending on the exact model of your Haulmark trailer, the cargo carrying portion may be designed for carrying such things as:

- A car
- Snowmobiles
- All-Terrain Vehicles (ATVs)
- Motorcycles

Do not transport people, containers of hazardous substances, cans or containers of flammable substances. However, fuel in the tank of an off-road vehicle, or a car or motorcycle, etc., may be carried inside of your enclosed cargo trailer.

WARNING

Never transport people inside your Haulmark trailer, even if it has living quarters. Besides putting their lives at risk, the transport of people may be illegal.

Section 4 - Loading The Trailer

⚠ WARNING

Do not transport flammable, explosive, poisonous or other dangerous materials in your trailer.

Exceptions:

- Fuel in the tanks of vehicles that are being towed.
- Fuel stored in proper containers used in trailer living quarters for cooking.
- Fuel stored in the tank of an on-board generator.

4.2.1 Preparing the Trailer for Loading

Before loading cargo into your trailer, inspect the interior of the trailer.

Trailers may be fitted with “D”-ring hold-downs, and/or a track system that can be used to secure the cargo. Inspect the “D”-rings and track system for looseness or signs of bending before loading the cargo onto the trailer.

⚠ WARNING

Damaged or loose “D”-rings can break, allowing cargo to become loose inside the trailer. Loose cargo can shift the center of gravity, and result in loss of control of the trailer.

Inspect “D”-rings, and test them for looseness before loading cargo.

Do not use a damaged or loose “D”-ring to secure cargo.

4.2.2 Loading the Trailer

Enclosed trailers may be fitted with a drop ramp door. The weight of the drop ramp door may be partially held by a spring and cable counterbalance assembly. If this assembly is out of adjustment or worn out, it will not provide the expected assistance for slow and careful lowering and raising of ramp.

⚠ WARNING

A spring and cable counterbalance can inflict serious injury if it breaks, or if incorrectly adjusted. Stand to the side when opening the door.

Inspect the cable and cable ends each time the door is operated.

Do not attempt to service the counterbalance. Take the trailer to your Haulmark dealer for service.

Carefully lower the drop ramp to the ground.

Load the cargo up the drop ramp and into the trailer, with approximately 70% of the cargo in front of the axle of a goose neck trailer, and 60% of the cargo in the front of the axle of a bumper pull trailer. If the trailer has living quarters, the cargo area of your trailer will have ventilation openings near the floor. Do not block these ventilation openings. These openings are provided to exhaust potentially deadly fumes.

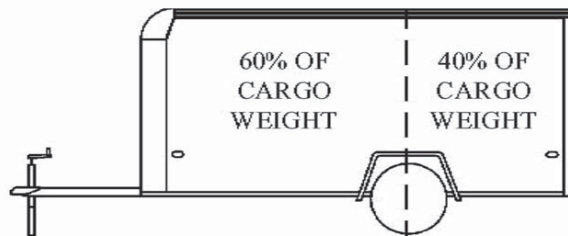
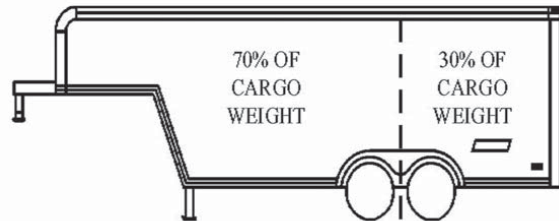

⚠ WARNING

Accumulation of hazardous fumes can cause death or serious injury.

Do not block access to ventilation ports.

Secure the cargo to the trailer using appropriate straps, chains and tensioning devices.

Close the drop ramp door and secure the trailer door catch using a linchpin or other locking device, so that the catch and door cannot open while the trailer is being towed.

 **WARNING**

**Always secure the door latch after closing.
Place a linchpin in the catch.**

**If the door opens, your cargo may be
ejected onto the road, resulting in death or
serious injury to other drivers.**

4.3 SECURING THE CARGO

Since the trailer cargo is subjected to longitudinal (front / back) and lateral (side / side) forces you must secure all cargo so that it does not shift while the trailer is being towed.

 **WARNING**

**A shifting load can result in failure, or to
loss of control of the trailer, and can lead to
death or serious injury.**

**You must tie down all loads with proper
sized fasteners, ropes, straps, etc. to
prevent the load from shifting while
trailerling.**

Section 5 - CHECKING THE TRAILER BEFORE AND DURING EACH TOW

5.1 PRE-TOW CHECKLIST

Before towing, double-check all of these items:

- Tires, wheels and lug nut tightness (torque) (see the “Safety Information” section starting on Page 1 of this manual).
- Tire Pressure. Inflate tires on trailer and tow vehicle to value indicated on Certification / VIN label.
- Coupler secured and locked ball (see the “Coupling to the Tow Vehicle” section starting at Page 23 of this manual).
- Safety chains properly rigged to tow vehicle, not to hitch or ball (see the “Coupling to the Tow Vehicle” section starting at Page 23 of this manual).
- Test Tail, Stop, and Turn Lights.
- Test trailer brakes.
- Safety breakaway switch lanyard fastened to tow vehicle, not to safety chains (see the “Coupling to the Tow Vehicle” chapter starting at Page 23 of this manual).

- Cargo properly loaded, balanced and tied down” (see the “Loading The Trailer” chapter starting at page 42 of this manual).
- Tongue weight and weight distribution set-up.
- Doors and gates latched and secured.
- Lock all doors that are equipped with keyed locks.
- Fire extinguisher.
- Flares and reflectors.

5.2 MAKE REGULAR STOPS

After each 50 miles, or one hour of towing, stop and check the following items:

- Coupler secured.
- Safety chains are fastened and not dragging.
- Cargo secured.
- Cargo door latched and secured.
- Check tires for signs of abnormal wear and loss of air pressure.

Section 6 - BREAKING-IN A NEW TRAILER

6.1 RETIGHTEN LUG NUTS AT FIRST 10, 25 & 50 MILES

Wheel lugs can shift and settle quickly after being first assembled, and must be checked after the **first** 10, 25 and 50 miles of driving. Failure to perform this check may result in a wheel coming loose from the trailer, causing a crash leading to death or serious injury. Refer to the “Inspection, Service & Maintenance” section for the proper tightening sequence and torque value for the wheel lugs nuts (bolts).

WARNING

Lug nuts are prone to loosen after being first assembled. Death or serious injury can result.

Check lug nuts for tightness on a new trailer, and after re-mounting a wheel at 10, 25 and 50 miles.

6.2 ADJUST BRAKE SHOES AT FIRST 200 MILES

WARNING

Brakes that are out of adjustment can result in death or serious injury.

Brakes must be adjusted at the intervals specified.

Brake shoes and drums experience a rapid initial wear. The brakes **must** be adjusted after the first 200 miles of use, and each 3,000 miles thereafter. Most axles are fitted with brake shoes that must be manually adjusted. Read your axle and brake manual to see if your brakes must be adjusted manually or if they adjust automatically. If you do not have the axle and brake manual, call Haulmark Industries, Inc. at 800-348-7530 for assistance.

To adjust the trailer brakes, see section 8.2.5.c, “Manually Adjusting Brake Shoes,” for instructions.

6.3 SYNCHRONIZING THE BRAKE SYSTEMS

Trailer brakes are designed to work in synchronization with the brakes on the tow vehicle.

When the tow vehicle and trailer braking systems are synchronized, both braking systems contribute to slowing, and the tongue of the trailer will neither dive nor rise sharply.

WARNING

If trailer and tow vehicle brakes do not work properly together, death or serious injury can occur.

Road test the brakes in a safe area at no more than 30 m.p.h. before each tow

To insure safe brake performance and synchronization, read and follow the axle/brake and the brake controller manufacturers’ instructions.

6.4 TIRE PRESSURE

Check tire pressures on both the trailer and tow vehicle. Inflate to the value indicated on the Certification /VIN label.

Section 7 - ACCESSORIES

This section provides some basic information for the safe operation of several accessories. For many accessories, such as generators and LP appliances, the manufacturer of the accessory has also provided instructions. You must read and follow these instructions before using the accessory. If you are uncertain whether you have all of the instructions, call Haulmark Industries, Inc. at 800-348-7530 or your dealer before operating the accessory. The following accessories are described in this section:

- Gasoline (or LP) and Diesel Generators
- Accessory Battery
- “Shore Power” connections which provide power by “plugging the trailer in” to an external source of electrical power
- LP Gas Fuel System
- Vending or Accessory Doors
- Electric-powered Landing Gear

Many accessories introduce the risk of fire and carbon monoxide poisoning. If you have an accessory on your trailer, make sure you have a fire extinguisher charged and ready before operating the accessory. Check the fire extinguisher at least once a month. If the fire extinguisher is discharged even partially, it must be recharged. Follow the fire extinguisher manufacturer’s instructions for recharging the extinguisher after use.

7.1 GASOLINE OR DIESEL-POWERED ELECTRIC GENERATORS

If your trailer is equipped with a generator, you must have and follow the generator manufacturer’s instructions. Carbon monoxide gas is present in the exhaust of all gasoline and diesel engines, as well as from other burning fuels such as LP gas and charcoal.

Carbon Monoxide is an odorless gas that can cause death. Be certain exhaust from any running engine or burning fuels can not accumulate in areas where people or animals are likely to be present. Conditions that can redirect exhaust fumes are, for example:

- Being drawn in by fans or ventilators operated in a trailer;
- Prevailing wind;
- Being trapped between adjacent trailers, vehicles or buildings; or
- Being trapped between or in a snow bank or other materials that can redirect fumes.

You must have an operating carbon monoxide detector inside the accommodation spaces of your trailer.

 WARNING
<p>Gasoline and diesel generators pose a risk of death from:</p> <ul style="list-style-type: none">• Carbon Monoxide• Fire and Explosion• Electrocution• Do not operate a generator without having a working carbon monoxide detector. <p>Do not refuel a running generator.</p> <p>Do not refuel near ignition sources.</p>

Before starting the generator, check fuel and oil levels. The generator may have to run for two or three minutes before it allows drawing electricity from it. Read the generator instruction manual. Never exceed the capacity of the generator.

Before turning off the generator, remove the electrical load and let the engine to run for two or three minutes to cool the generator.

7.2 ACCESSORY BATTERY

Your trailer may be outfitted with an accessory battery that operates lighting, electric landing gear, slide-outs or other accessories. An accessory battery may be kept charged either by the tow vehicle or by the generator or shore power.

A disconnect switch may be provided to disconnect the accessory battery when you do not plan to be using the trailer for an extended period, such as seasonal storage. If there is no disconnect switch, then remove the cables from the battery terminals.

The accessory battery must be kept in a charged condition during storage. The battery could freeze and break if it becomes discharged.

7.3 SHORE POWER

Shore power is the delivery of electrical power from another source to a power inlet on your trailer. To connect your trailer to this source, you must have a “shore power” cord, specifically designed for this use. **DO NOT USE AN ORDINARY EXTENSION CORD.**

Section 7 - Accessories

The trailer end of this cord is connected to an electrical box on the trailer, sometimes referred to as a “motor base.” This box contains circuit breakers and/or fuses and may include a power converter to change the shore power (usually 110 volts alternating current) into 12 volts direct current.

Do not assume that a shore power supply is correctly wired. Shore power may have incorrect polarity or not have the safety ground. Before connecting your trailer, test shore power by using a polarity and ground tester, which can be purchased at electronic stores.

If you have shore power, your trailer may be fitted with Ground-Fault Interrupting outlets (GFI). If you have GFI protection, you must periodically test the outlets by pressing the “TEST” button that is located on the GFI-equipped outlet.

WARNING

Shore power poses a risk of death due to electrocution.

Always use a grounded connection.

Never connect to an ungrounded source of shore power.

Never remove the “third prong” from the shore power plug.

WARNING

- Risk of fire.
- Connect only to source of correct voltage.
- Do not overload electrical circuits.
- Do not use an extension cord to connect to shore power.
- Replace fuses with like rating.

7.4 LP GAS FUEL SYSTEM

When LP gas is used in a living quarters environment, our living quarters meet ANSI 1.14.2 and NFPA 11.9.2 standards.

LP gas systems are installed to operate a variety of appliances, such as stoves, refrigerators, heating units and electrical generators. The exhaust fumes from burning LP gas contain carbon monoxide. Carbon monoxide gas is odorless and can cause death or serious brain injury if inhaled. The exhaust from LP appliances must be directed to the outdoors. You must have an

operating carbon monoxide detector in the accommodation space of your trailer.

DANGER

You can die or be brain damaged by Carbon Monoxide.

Make certain the exhaust from LP appliances is directed to the outdoors.

Have a working carbon monoxide detector in the accommodation spaces of your trailer before operating any LP gas appliance.

Do not operate portable grills, portable stoves, portable lanterns or portable heaters inside the trailer.

When used for the first time, or after a period of storage, the LP gas lines will be full of air and must be purged of air, before the appliances will stay lit. Have the LP gas lines purged by your trailer dealer, or an LP gas dealer.

An LP gas system is designed to operate with a supply of LP gas only, NOT natural gas. A natural gas supply is unsafe for the system’s pressure regulation devices.

WARNING

Risk of death due to fire or explosion.

Do not connect an LP gas system to a supply of natural gas.

Extinguish all pilot lights and turn off all appliances before refilling fuel or LP gas tanks.

Do not fill the tank with any gas other than LP (butane or propane).

Do not store LP gas tanks inside the trailer.

Keep the shutoff valve on your LP gas tank closed at all times, except when you are operating an LP gas appliance. Before opening the LP shutoff valve, turn off all LP gas appliances. If an appliance is on when you open the shutoff valve, LP gas can accumulate in the trailer, which can result in an explosion.

Do not use a wrench to open or close the shutoff valve. If the shutoff does not completely stop the flow of LP gas when it is hand-tightened, replace the shutoff valve.

LP gas leaks can result in fire or explosion. If your trailer is equipped with an LP gas system, it must also be equipped with an LP gas detector. The LP gas detector

Section 7 - Accessories

will be located near the floor to detect the heavier-than-air LP gas. If a leak is suspected, use a soapy water solution to search for the leak. Do not use a solution that contains ammonia or chlorine (common in window and other household cleaning compounds), because those chemicals will cause LP piping corrosion.

WARNING

Risk of fire or explosion

If LP gas is detected (by smell or by the LP gas detector):

- Do not touch electrical switches
- Extinguish flames and pilot lights
- Open doors for ventilation
- Shut off LP gas supply at the LP tank
- Leave the area until odor clears

Correct the source of LP gas leakage before using LP appliances.

Do not use a flame to locate the source of an LP gas leak.

LP gas is either propane or butane that is compressed into liquid form. LP gas must be completely vaporized before being burned. Butane gas will not operate if the outside temperature is below 32 degrees Fahrenheit.

NOTICE

Use Butane only when the temperature is above freezing (32 degrees F).

Propane gas will operate at temperatures as low as minus 44 degrees Fahrenheit (-44 F).

Keep the regulator for the LP gas system (located near the LP gas tank) covered with a guard to protect it from road debris.

LP gas is prohibited on some roadways, bridges and tunnels. Check a map and with Department of Transportation (or with the AAA) for travel routes that do not have such restrictions.

7.4.1 LP Gas System Troubleshooting

- Having liquid “gas” at your appliance is an indication that the LP gas tank is overfilled, or that the temperature is too cold.
- If your LP gas appliances do not stay lit, it might be because your LP gas system is contaminated with

air or moisture. Many LP gas vendors have facilities to purge the air from an LP gas system.

- If your LP gas system is not providing gas, even when the shutoff valve is open, it might be because the LP gas regulator has frozen water in it.

WARNING

Risk of fire or explosion.

Never use a flame, heat lamp or hair dryer to thaw an LP gas regulator.

Use an incandescent light bulb to warm the regulator.

Do not remove the regulator cover or attempt to service the LP gas regulator.

7.5 VENDING & ACCESSORY DOORS

A vending or accessory door opens vertically and has a hinge along its top edge. These heavy doors are equipped with spring-assisted lifting, usually with a device known as a “gas spring.”

The gas spring lifting device is not designed to hold a vending door up. You must use the provided solid “prop rods” to hold a vending door in the open position.

WARNING

Gas springs lose their lifting capability with age and cold weather; and can cause the door to fall, resulting in injury.

Always hold the door open until the prop rods are in place.

Always use prop rods to hold vending or accessory doors open.

Be prepared to hold the weight of the door when removing prop rods.

7.6 ELECTRIC- POWERED LANDING GEAR

The landing gear (also known as the jack) on your trailer may be powered with an electric motor. The landing gear is operated up or down using controls located near the landing gear.

If the motor does not operate, such as when the battery is fully discharged, the landing gear can be operated manually with a socket wrench.

Section 8 - INSPECTION, SERVICE & MAINTENANCE

8.1 INSPECTION, SERVICE & MAINTENANCE SUMMARY CHARTS

You must inspect, maintain and service your trailer regularly to insure safe and reliable operation. If you cannot or are unsure how to perform the items listed here, have your dealer do them. Note: In addition to this manual, also check the relevant component manufacturer's manual.

Haulmark Trailer Inspection and Service Intervals							
Item	Service Required	Manual Section Reference	Service Interval				
			Before Each Use	Every 3 Mo's	Every 6 Mo's	Every Year	
Axle Attachment Bolts	Check by dealer.	8.2.1			•		
Breakaway Brakes	Check operation.	3.2.1.e, 3.2.2.d, 3.2.3.c	•				
Breakaway Battery	Fully charged, connections clean	8.2.5.c	•				
Breakaway Switch	Test operation, connections clean	8.2.5.c	•				
Brakes, all types	Check operation.	8.2.5	•				
Shoes and Drums	Adjust.	8.2.5.b	First 200 mi., ea. 3,000 miles				
	Check for scoring and wear.				•		
Brakes, Electric							
Magnets	Inspect for wear and current draw.	Manufacturer	6 months or 6,000 miles				
Controller (in tow vehicle)	Check for correct amperage and modulation.	Manufacturer	6 months or 6,000 miles				
Brakes, Hydraulic	Check fluid level & replenish. Check for leaks/sticking.	8.2.5.d					
Master Cylinder	Inspect for cracks, leaks, kinks.	8.2.5.e8.2.5.d	12 months or 12,000 miles				
Brake Lines	Verify operation/inspect.		12 months or 12, 000 miles				
Air Pressure Actuated	Inspect for cracks, leaks, kinks.		12 months or 12,000 miles				
Electric Actuated	Verify operation/inspect.	Manufacturer	12 months or 12, 000 miles				
Coupler and Hitch Ball	Check for cracks, pits, flats. Replace w/ball & coupler having GVW. Grease. Check locking device & replace when worn.	8.2.6.a	•				
Gooseneck Coupler and Ball	Check for cracks, pits, flats. Replace w/ball & coupler having GVW. Grease. Check locking device & replace when worn.	8.2.6.b	•				
Fifth Wheel and Pin	Grease. Replace when worn.	8.2.6.c	•				
Jack, Drop Leg	Grease gears at top.	8.2.7					•

Section 8 - Inspection, Service & Maintenance

Haulmark Trailer Inspection and Service Intervals						
Item	Service Required	Manual Section Reference	Service Interval			
			Before Each Use	Every 3 Mo's	Every 6 Mo's	Every Year
Lights and Signals	Check for proper operation. Verify connection is clean and tight.	8.2.8	•			
Structure						
Trailer body	Wash as needed to remove salt and liquid de-icer	8.2.2				
Hinges, doors and dividers	Inspect. Repair or replace damaged, worn or broken parts.			•		
Frame members	Inspect all frame members, bolts & rivets. Repair or replace damaged, worn or broken parts.	8.2.2.a				•
Welds	Inspect all welds. Repair as needed.	8.2.2.b				•
Slide-Out	Clean dirt buildup. Lubricate slides, shafts and gears.	8.2.4				•
Roof Vents	Clean dirt buildup. Lubricate hinges.				•	
Windows	Clean dirt buildup. Lubricate window slides.				•	
Tires						
	Check tire pressure when cold. Inflate as needed.	8.2.11	•			
	Rotate tires.		Every 5,000 miles			
	Inspect treads & sidewalls thoroughly. Replace tire when treads are worn or a sidewall has a bulge.	8.2.11		•		
Wheel Bearings (Hubs)						
Standard Bearings	Disassemble, inspect and re-pack.	8.2.13.a	Every 12,000 mi. or 1 yr			
E-Z Lube® or Other Grease Fitting Lubricated Bearings	Check for free running and lubricate.	8.2.13.b	Every 12,000 mi. or 1 yr.			
Nev-R-Lube™ or Other Sealed Bearings	Check for excessive wear, replace if necessary.	Manufacturer	Every 12,000 mi. or 1 yr.			
Lug Bolts and Hub	Check and tighten.	8.2.15	Check for tightness before every use. Check torque; After first 10, 25 & 50 miles; After any impact; Annually; & At start of towing season			
Rims	Inspect for cracks & dents. Replace as needed.	8.2.12	After any impact or 1 yr.			

8.2 INSPECTION AND SERVICE INSTRUCTIONS

8.2.1 Axle Bolts, Frame, Suspension, & Structure

⚠ WARNING

Worn or broken suspension parts can cause loss of control and injury may result.
Have trailer professionally inspected annually and after any impact.

To perform many of the inspection and maintenance activities, you must jack up the trailer. Figure 8-1 indicates the general areas where jacks and jack stands may be applied.

When jacking and using jack stands, place them so as to clear wiring, brake lines, and suspension parts (springs, torsion bars, etc.). Place jacks and jack stands inside of the perimeter strip on the supporting structure to which the axles are attached.

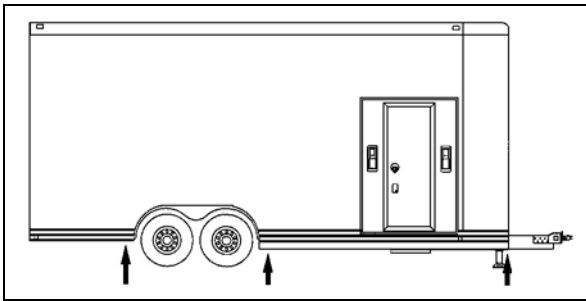

Jacking Points for Trailer - Figure 8-1

⚠ WARNING

Never crawl under your trailer unless it is on firm and level ground and resting on properly placed and secured jack stands.

8.2.2 Trailer Structure

Wash the entire trailer thoroughly immediately after exposure to road salt and liquid deicer. The salt and liquid deicer will corrode and pit the aluminum.

Because the trailer floor receives the most abuse, it will most likely corrode before any other part of the structure.

8.2.2.a Fasteners and Frame Members

Inspect all of the fasteners and structural frame members for bending and other damage, cracks, or failure. Repair or replace any damaged fastener and repair the frame member. If you have any questions about the condition or method of repair of fasteners or frame members, get the recommendation of, or have the repair done by, your dealer.

The various fastener types used on your trailer are:

- Bolts, which are used mainly for attaching door and gate hinges to the trailer body;
- Buck Rivets, which are used to attach the sides and roof panels of the body to each other, and to the frame of the trailer

⚠ WARNING

Broken or damaged fasteners or welds can cause injury or damage to trailer and contents.
Inspect trailer before each use and repair or replace all damaged parts.

8.2.2.b Welds

All welds can crack or fail when subjected to heavy loads or movement of cargo that was not properly tied to prevent movement. Any time that you know or suspect that the trailer has been subjected to heavy loads or movement of cargo, immediately inspect the welds and fasteners for damage. To prevent severe damage to your trailer, inspect all of the welds for cracks or failure at least once a year.

⚠ WARNING

Do not attempt to repair a cracked or broken weld unless you have the skills and equipment to make a proper repair.
Improper weld repair will lead to early failure of the trailer structure and serious injury or death.
Go to your Haulmark dealer.

Section 8 - Inspection, Service & Maintenance

WARNING

Broken or damaged fasteners or welds can cause injury or damage to trailer and contents.

Inspect trailer before each use and repair or replace all damaged parts.

8.2.3 Drop Ramp Torsion Springs

If your trailer has a drop-ramp door, the weight of the door may be partially held by a torsion spring and a cable. Stand to the side when opening the drop ramp. You could be hurt if you are behind the drop ramp and the counterbalance does not work.

WARNING

A spring and cable counterbalance can inflict serious injury if it breaks, or if incorrectly adjusted.

Inspect the cable and cable ends each time the door is operated.

Do not attempt to service the counterbalance. Take the trailer to your Haulmark dealer for service.

Inspect the cable and cable ends regularly for fraying and signs of loosening. If released, a torsion spring can inflict serious injury.

The torsion spring and cable are not user serviceable. The torsion spring must be serviced by a person who is trained in torsion spring safety.

8.2.4 Slide-Outs

The optional slide-out facility is fitted with shafts, bushing, gears and sliding members located on the underside of the trailer. These parts are exposed to road grime, water and possible salt spray. Clean and lubricate the moving parts regularly to keep the slide-out from seizing.

Follow the instructions below to clean and lubricate the slide-out mechanism at least once per season, and more frequently if your trailer is operated in dusty or salt-spray environments.

- Clean the locations where the drive shaft passes through the bushings.
- Hand pack grease on the gears.
- Grease the sliding track.

8.2.5 Trailer Brakes

8.2.5.a Initial Inspection

WARNING

Brakes that are out of adjustment can result in death or serious injury.

Brakes must be adjusted at the intervals specified.

The brake shoes must be adjusted after the first 200 miles of use, and each 3,000 miles thereafter.

Most axles are **not** fitted with a brake mechanism that will adjust the brakes. Brakes must be adjusted manually. It is critical that the brakes be adjusted at the specified intervals. Brakes that are out of adjustment can cause a collision, which may result in death or serious injury.

8.2.5.b Periodic Inspection

Properly functioning brake shoes and drums are essential to ensure safety. You must have your dealer inspect these components at least once per year, or each 12,000 miles.

8.2.5.c Manually Adjusting Brake Shoes

Most braking systems require periodic adjustment. Read your axle and brake manual to see how to adjust your brakes. If you do not have this manual, call Haulmark Industries, Inc. at 800-348-7530 or your dealer for assistance.

The following steps apply to adjust most manually adjustable brakes. If you are unsure or do not understand how to adjust your brakes, have the brakes adjusted by your dealer. Properly adjusted brakes are critical for safety.

- Jack up the trailer and secure it on adequate capacity jack stands.
- Be sure the wheel and brake drum rotate freely.
- Remove the adjusting-hole cover from the adjusting slot on the bottom of the brake backing plate.
- With a screwdriver or standard adjusting tool, rotate the starwheel of the adjuster assembly to expand the brake shoes. Adjust the brake shoes out until the pressure of the linings against the drum makes the wheel very difficult to turn.
- Note: Your trailer maybe equipped with drop spindle axles. See axle manual for your axle type. You will need a modified adjusting tool for adjusting the brakes in these axles. With drop spindle axles, a modified adjusting tool with about an 80 degree angle should be used.

Section 8 - Inspection, Service & Maintenance

- Rotate the starwheel in the opposite direction until the wheel turns freely with a slight drag.
- Replace the adjusting-hole cover.
- Repeat the above procedure on all brakes.
- Lower the trailer to the ground.

8.2.5.d Brakes, Electric

Two different types of electric brakes may be present on the trailer: an emergency electric breakaway system, which acts only if the trailer comes loose from the hitch and the breakaway pin is pulled. The other brake is an electric braking system that acts whenever the brakes of the tow vehicle are applied.

Breakaway Battery

This battery supplies the power to operate the trailer brakes if the trailer uncouples from the tow vehicle. Be sure to check, maintain and replace the battery according to the battery manufacturer's instructions.

Breakaway Switch

This switch causes the breakaway battery to operate the electric brakes if the trailer uncouples from the tow vehicle.

The lanyard for the pull pin is connected to the tow vehicle, and the switch is connected to the trailer. To check for proper functioning of the switch, battery and brakes, you must pull the pin from the switch and confirm that the brakes apply to each wheel. You can do this by trying to pull the trailer with the tow vehicle, after pulling the pin. The trailer brakes may not lock, but you will notice that a greater force is needed to pull the trailer.

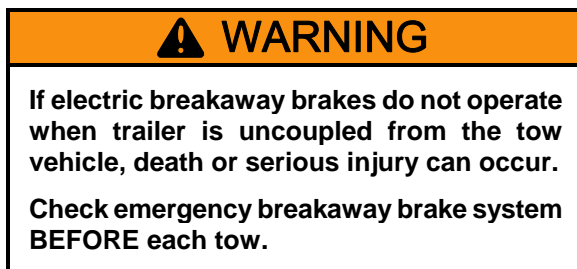

Tow Vehicle Operated Electric Brakes

The electric brakes that operate in conjunction with the tow vehicle brakes must be "synchronized" so that braking is properly distributed to the tow vehicle brakes and the trailer brakes. For proper operation and synchronization, read and follow the axle/brake and the brake controller manufacturers' instructions.

Magnets for all Electric Brakes

To make certain an electrically-operated braking system will function properly, you must have your dealer inspect the magnets at least once a year, or each 12,000 miles. See the brake manual for wear and current inspection instructions.

8.2.5.e Brakes, Hydraulic (Air or Electric Operated)

If your trailer has hydraulically-operated brakes, they function the same way the hydraulic brakes do on your tow vehicle. The hydraulic braking system must be inspected by a dealer, at least as often as the brakes on the tow vehicle, but no less than once per year. This inspection includes an assessment of the condition and proper operation of the wheel cylinders, brake shoes, brake drums and hubs.

You must check the fluid level in the master cylinder reservoir at least every three months. If you tow your trailer an average of 1,000 miles per month in a hot and dry environment, you must check the brake fluid level once a month. The brake fluid reservoir is located on the tongue of the trailer or near the gooseneck. Fill with DOT 4 brake fluid.

Air Pressure-Operated Hydraulic

Air/hydraulic braking systems are typically used when the tow vehicle has a diesel engine. The tow vehicle has an air compressor that routes the air to an air/hydraulic mechanism, which sends brake fluid to the wheel cylinders.

The air pressure gauge in your tow vehicle indicates the current air pressure. See your tow vehicle manual for the proper air pressure.

Electrical-Operated Hydraulic

Electric/hydraulic braking systems, which are mounted on the trailer, use a small electrically-driven pump to generate hydraulic pressure, which operates the brake cylinders. Like electrical brakes, an electric/hydraulic braking system is operated by an electrical signal from the tow vehicle.

8.2.6 Trailer Connection to Tow Vehicle

8.2.6.a Coupler and Ball

The coupler on the trailer connects to the ball attached to the hitch on the tow vehicle. The coupler, ball and hitch transfer the towing forces between the tow vehicle and the trailer. Before each tow, coat the ball with a thin layer of automotive bearing grease to reduce wear and ensure proper operation; and check the locking device that secures the coupler to the ball for proper operation.

Section 8 - Inspection, Service & Maintenance

If you see or feel evidence of wear, such as flat spots, deformations, pitting or corrosion, on the ball or coupler, immediately have your dealer inspect them to determine the proper action to prevent possible failure of the ball and coupler system. All bent or broken coupler parts must be replaced before towing the trailer.

The coupler handle lever must be able to rotate freely and automatically snap into the latched position. Oil the pivot points, sliding surfaces, and spring ends with SAE 30W motor oil. Keep the ball pocket and latch mechanism clean. Dirt or contamination can prevent proper operation of the latching mechanism.

When replacing a ball, the load rating must match or exceed the GVWR of the trailer.

8.2.6.b Gooseneck

The gooseneck receiver on the trailer connects to a hitch-mounted ball on the towing vehicle. The receiver, ball and hitch transfer the towing forces between the tow vehicle and the trailer. Before each tow, coat the ball with a thin layer of automotive bearing grease to reduce wear and ensure proper operation; and check the locking device that secures the receiver to the ball for proper operation.

If you see or can feel evidence of wear, such as flat spots, pitting or corrosion, on the ball or receiver, immediately have your dealer inspect them to determine the proper action to prevent possible failure of the ball and receiver system.

When replacing a ball, the load rating must match or exceed the GVWR of the trailer.

8.2.6.c Fifth Wheel Kingpin

Before each tow, inspect the fifth wheel and kingpin for wear, and coat the contact surface of the fifth wheel plate with water-resistant Lithium-base grease. If you see evidence of wear on the fifth wheel or kingpin, immediately have your dealer inspect them to determine the proper action to prevent failure of the fifth wheel and kingpin system.

8.2.7 Landing Leg or Jack

If a grease fitting is present, you must use a grease gun to lubricate the jack mechanism. Grease the gears in the top of hand-cranked jacks once a year, by removing the top of the jack and pumping or hand packing grease into the gears.

8.2.8 Lights and Signals

Before each tow, check the trailer taillights, stoplights, turn signals and any clearance lights for proper operation.

WARNING

To avoid collisions, taillights, stoplights and turn signals must work.

8.2.9 Accessory Battery

Your trailer may be outfitted with an accessory battery that operates lighting, electric landing gear, slide-outs or other accessories. An accessory battery may be kept charged either by the tow vehicle or by the generator or shore power. See the manual for the accessory battery.

A disconnect switch may be provided to disconnect the accessory battery when you do not plan to be using the trailer for an extended period, such as seasonal storage. If there is no disconnect switch, then remove the cables from the battery terminals.

The accessory battery must be kept in a charged condition during storage. The battery could freeze and break if it becomes discharged.

8.2.10 Tires

Before each tow, be sure the tire pressure is at the value indicated on the Certification / VIN label. Tire pressure must be checked while the tire is cold. Do not check the tire pressure immediately after towing the trailer. Allow at least three hours for a tire to cool, if the trailer has been towed for as much as one mile. Replace the tire before towing the trailer if the tire treads have less than 2/32 inch depth or the telltale bands are visible.

A bubble, cut or bulge in a side wall can result in a tire blowout. Inspect both side walls of each tire for any bubble, cut or bulge; and replace a damaged tire before towing the trailer.

WARNING

Worn, damaged or under-inflated tires can cause loss of control, injury and damage.

Check tires before each tow.

8.2.11 Wheel Rims

If the trailer has been struck, or impacted, on or near the wheels, or if the trailer has struck a curb, inspect the rims for damage (i.e. being out of round); and replace any damaged wheel. Inspect the wheels for damage every year, even if no obvious impact has occurred.

Never install aftermarket wheels or lug nuts on your trailer. Use only original equipment wheels and lugs nuts. Aftermarket wheels and lug nuts may not meet the

Section 8 - Inspection, Service & Maintenance

load carrying requirements, pressure capacity and offset as the original equipment.

8.2.12 Wheel Liners (Simulators)

Your trailer may be equipped with wheel liners (simulators). See figure 8-4. To remove the liners to access the wheel lugs:

1. Locate the two removable jam nuts (1). These nuts will have a crimp mark on every other hex and are 180 degrees apart.
2. Remove the jam nuts. Do not use power tools on jam nuts.
3. Remove the hub cover (2), wheel liner (3), spacers (4) and stud extenders (5).

To install the liners:

1. Install stud extenders (5) 180 degrees apart and tighten to 30 lb. ft. of torque.
2. Install spacers (4), wheel liner (3), hub cover (2) and jam nuts (1). Tighten jam nuts to 30 lb. ft. of torque.

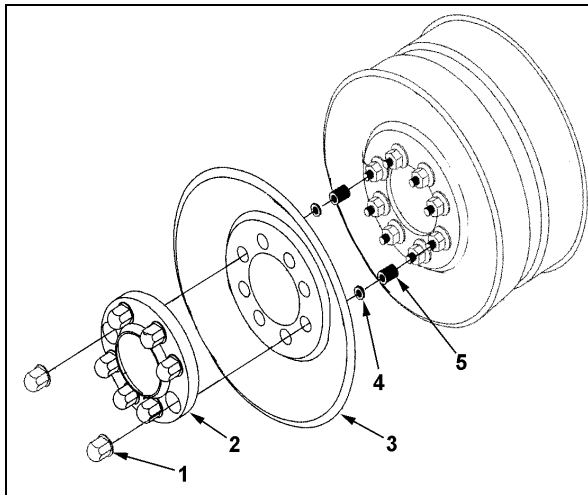

Wheel Simulator - Figure 8-4

8.2.13 Wheel Bearings

A loose, worn or damaged wheel bearing is the most common cause of brakes that grab.

To check your bearings, jack trailer and check wheels for side-to-side looseness. If the wheels are loose, or spin with a wobble, the bearings must be serviced or replaced.

Your trailer will be equipped with one of the following types of wheel bearings:

- Standard – Bearing are lubricated by grease or oil.
- E-Z Lube® or other grease fitting lubricated bearings - Bearings are lubricated by grease and are identified by a grease fitting on the end of the axle.

- Nev-R-Lube™ or other sealed bearings – The bearings are sealed are require no routine lubrication.
- Refer to this manual and the axle manufacturer's information for inspection and service information.

8.2.13.a Standard Bearings

Bearing Lubrication – Grease

Disassemble, inspect and re-pack the wheel bearings every 12 months or 12,000 miles, whichever occurs first.

If a trailer wheel bearing is immersed in water, it must be repacked after each immersion.

If your trailer has not been used for an extended amount of time, have the bearings inspected and packed more frequently, at least every six months and prior to use.

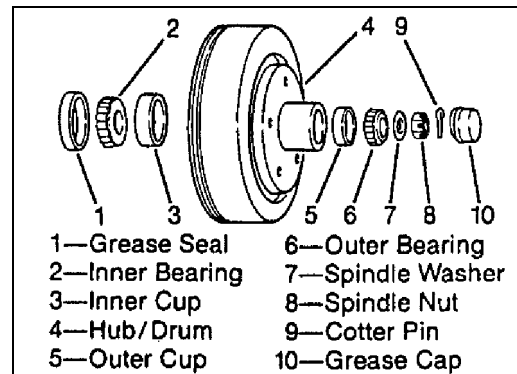

Standard Wheel Bearing - figure 8-5

Follow the steps below to disassemble and service the wheel bearings.

- After removing the grease cap, cotter pin, spindle nut and spindle washer (items 7-10 in "Standard Wheel Bearing" figure 8-5), remove the hub and drum to inspect the bearings for wear and damage.
- Replace bearings that have flat spots on rollers, broken roller cages, rust or pitting. Always replace bearings and cups in sets. The inner and outer bearings are to be replaced at the same time.
- Replace seals that have nicks, tears or wear.
- Pack the bearings with a high quality EP-2 automotive wheel bearing grease.

Every time the wheel hub is removed and the bearings are reassembled, follow the steps below to check the wheel bearings for free running and adjust.

- Turn the hub slowly, by hand, while tightening the spindle nut, until you can no longer turn the hub by hand.

Section 8 - Inspection, Service & Maintenance

- Loosen the spindle nut just until you are able to turn it (the spindle nut) by hand. Do not turn the hub while the spindle nut is loose.
- Put a new cotter pin through the spindle nut and axle.
- Check the adjustments. Both the hub and the spindle nut should be able to move freely (the spindle nut motion will be limited by the cotter pin).

Bearing Lubrication – Oil

If your trailer is equipped with oil lubricated bearings, check the oil level every 6 months or 6,000 miles, whichever occurs first.

The oil can be filled through the oil fill hole in the hub or cap. Fill to the level indicated on the hub or cap.

8.2.13.b E-Z Lube® or Other Grease Fitting Lubricated Bearings

Bearings should be lubricated every 12 months or 12,000 miles, whichever occurs first.

- Remove the rubber plug (if equipped) from the hub end.
- Place a standard grease gun onto the grease fitting. Make sure the grease gun nozzle is fully seated on the fitting.
- Pump grease into the fitting while rotating hub or drum. The old displaced grease will begin to flow back out to the cap around the grease gun nozzle.
- Stop when new grease is observed.
- Wipe off excess and install rubber plug. See figure 8-6.

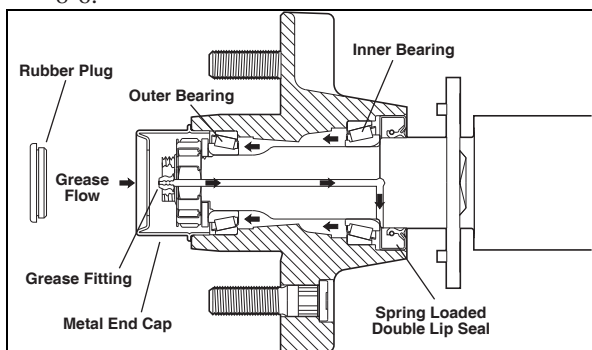

E-Z Lube® Bearing Shown - Figure 8-6

8.2.13.c Nev-R-Lube™ or Other Sealed Bearings

Bearing should be inspected every 12 months or 12,000 miles, whichever occurs first. Refer to the axle manufacturer's manual for information on checking wheel end play and clearance. See figure 8-7.

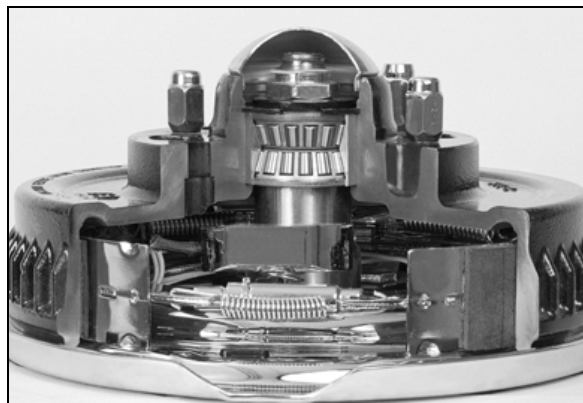

Nev-R-Lube™ Bearing Shown - Figure 8-7

8.2.14 Lug Nuts (Bolts)

Lug nuts are prone to loosen right after a wheel is mounted to a hub. When driving on a remounted wheel, check to see if the lug nuts are tight after the first 10, 25 and 50 miles of driving and before each tow thereafter.

Lug Nut Tightening (Torque)

Being sure wheel mounting nuts (lug nuts) on trailer wheels are tight and properly torqued is an important responsibility that trailer owners and users need to be familiar with and practice. Inadequate and/or inappropriate wheel nut torque (tightness) is a major reason that lug nuts loosen in service. Loose lug nuts can rapidly lead to a wheel separation with potentially serious safety consequences.

- Be certain you have a clear understanding of the specific wheel maintenance responsibilities your vehicle manufacturer requires/recommends you, as the owner, must perform in order to insure your wheel equipment is safely maintained. Check the lug nut tightness the first 10, 25 and 50 miles of driving and before each tow thereafter. Refer to the owner's manual and speak with your dealer if you have any questions about proper tightening practices.
- The only way to be certain you have checked the tightness or torqued the lug nuts to the proper value is with a torque wrench. Four-way wrenches, ratchets, and similar tools can be useful for short-term emergency repairs but are not appropriate tools for accurately checking lug nut torque. You must use a torque wrench to accurately indicate the torque that you are applying to the lug nut.
- Keep a record of the date and approximate mileage when you check the lug nut torque. Note any lug nut that has lost torque. Investigate the reason(s) if the lug nut torque is not maintained after more than one re-torque application, because this indicates there is something wrong with the lug nuts, nut studs, wheels and/or hubs and should be corrected.

Section 8 - Inspection, Service & Maintenance

- Contact your dealer or vehicle manufacturer immediately if you experience any persistent lug nut loosening or any other lug, wheel or axle problems.
- If you find any loose lug nuts while tightening, remove the wheel(s) and take them to your dealer for inspection. The wheel may be damaged and if so, must be replaced. Lug nuts on a damaged wheel holes will not retain tightness.
- In the event of a wheel separation incident, notify the vehicle manufacturer and dealer. Seek prompt professional assistance in assessing the trailer and its gear, and retain, but don't re-use involved lugs, wheels and studs. Don't repair or service the trailer yourself. Contact a trained technician.

⚠ WARNING

Lug nuts are prone to loosen after being first assembled. Death or serious injury can result.

Check lug nuts for tightness on a new trailer, and after re-mounting a wheel at 10, 25 and 50 miles.

⚠ WARNING

Metal creep between the wheel rim and lug nuts (bolts) will cause rim to loosen.

Death or injury can occur if wheel comes off.

Tighten lug nuts (bolts) before each tow.

Tighten the lug nuts to the proper tightness to prevent wheels from coming loose. Refer to the steps that follow and the axle manufacturer's information. Use a calibrated torque wrench to tighten the lug nuts. Over-tightening may result in breaking the studs or permanently deforming the mounting stud holes in the wheels.

Remove all excess paint, oil and grease from mounting surfaces.

Start all lug nuts by hand to prevent cross threading.

Tighten lug nuts in sequence shown in "Lug Nut Sequence of Tightening" figure 8-8.

Never install aftermarket wheels or lug nuts on your trailer. Use only original equipment wheels and lugs nuts. Aftermarket wheels and lug nuts may not meet the load carrying requirements, pressure capacity and offset as the original equipment.

Never install aluminum wheels on hubs/studs that were designed for steel wheels. The stud length required for aluminum wheels is greater than that required for steel wheels.

⚠ WARNING

Aftermarket wheels may part from the trailer, resulting in death or serious injury.

Never install aftermarket wheels or lug nuts on your Haulmark trailer.

Never install aluminum wheels on hubs/studs that were designed for steel wheels.

⚠ WARNING

Information or torque values stamped on lug nuts supersedes the information listed in this manual.

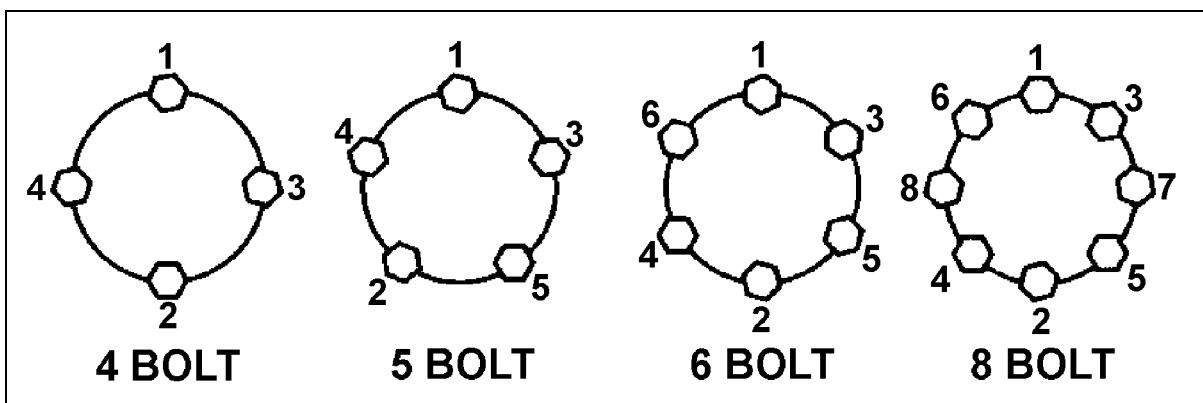

Section 8 - Inspection, Service & Maintenance

Lug Nut Sequence of Tightening - Figure 8-8

Lug Nut Torque			
Stud size	1st stage	2nd Stage	3rd Stage
1/2 Inch	35 lb ft	65 lb ft	100 lb ft
9/16 Inch	45 lb ft	90 lb ft	130 lb ft
5/8 Inch	70 lb ft	140 lb ft	200 lb ft
5/8 Inch Flanged	100 lb ft	200 lb ft	300 lb ft
3/4 Inch Flanged	135 lb ft	270 lb ft	400 lb ft

Lug Nut Torque - Figure 8-9

Lug nuts are prone to loosen right after a wheel is mounted to a hub. When driving on a remounted wheel, check to see if the lug nuts are tight after the first 10, 25 and 50 miles of driving and before each tow thereafter.

⚠ WARNING

Lug nuts are prone to loosen after being first assembled. Death or serious injury can result.

Check lug nuts for tightness on a new trailer, and after re-mounting a wheel at 10, 25 and 50 miles.

⚠ WARNING

Metal creep between the wheel rim and lug nuts (bolts) will cause rim to loosen.

Death or injury can occur if wheel comes off.

Tighten lug nuts (bolts) before each tow.

Section 9 - TECHNICAL REFERENCE

9.1 TRAILER LIGHTING ELECTRICAL CONNECTION

The electrical wiring on your Haulmark trailer has been designed and built in accordance with all the Federal Motor Vehicle Safety Standards that were in effect when the trailer was produced.

Wiring: Your tow vehicle must have the correct plug at the rear and must be connected to the correct tow vehicle circuits for the vehicle to correctly tow the trailer. Trailers not equipped with brakes will have a 4-way fl at plug and all other trailers will have a larger 7-way round plug.

The figure below illustrates the wiring code that has been adopted for several types of electrical lighting connectors.

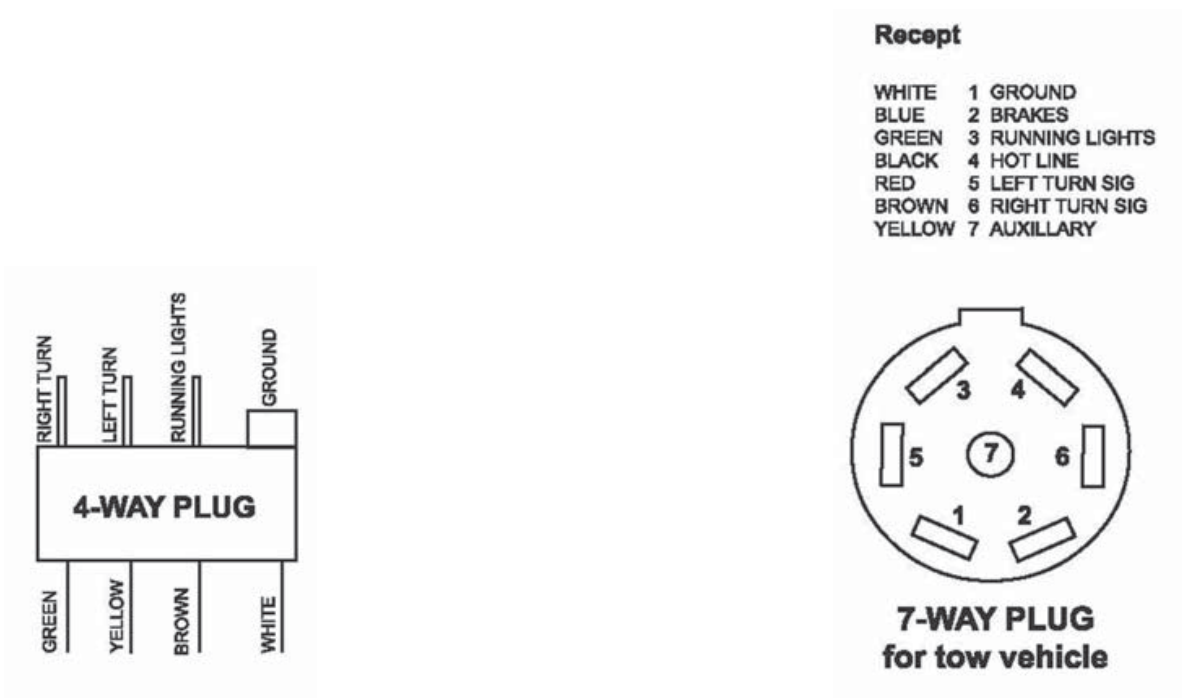

It is very important that you have a ground wire running from the plug to the frame of your tow vehicle. Hitches, safety chains and couplers are not adequate grounds for your trailer. If an auxiliary battery is added to your trailer, there must be a fuse installed between the battery and the trailer. If you have any questions regarding the wiring of either your tow vehicle or your trailer, contact either your dealer or Haulmark.

Section 9 - Technical Reference

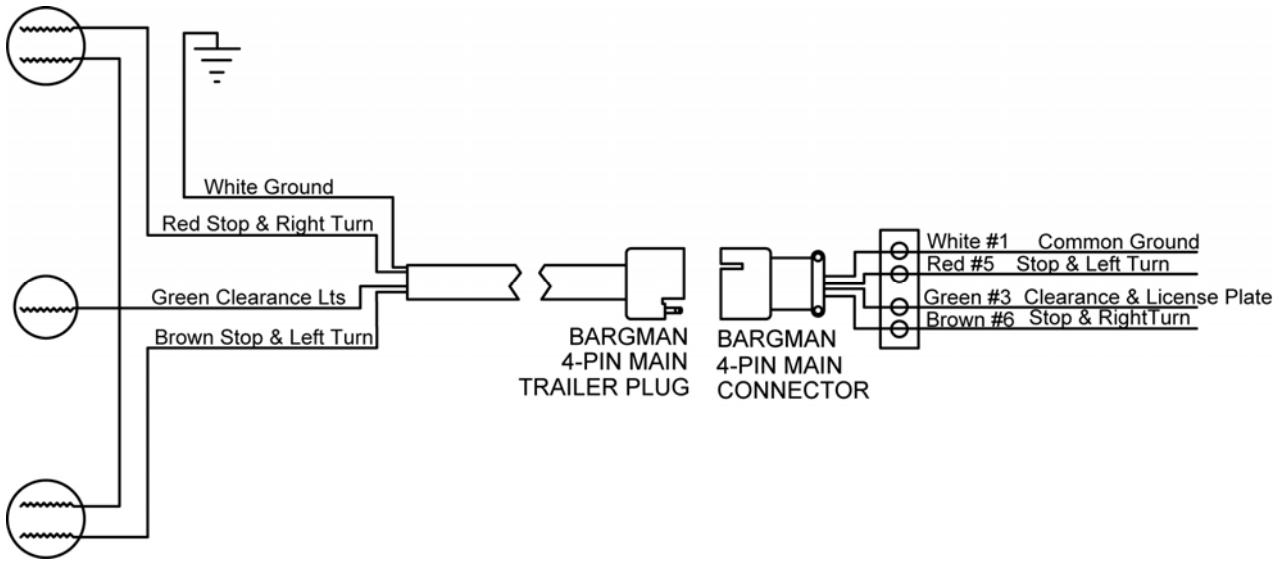

Bargman 4 Circuit Harness Connector

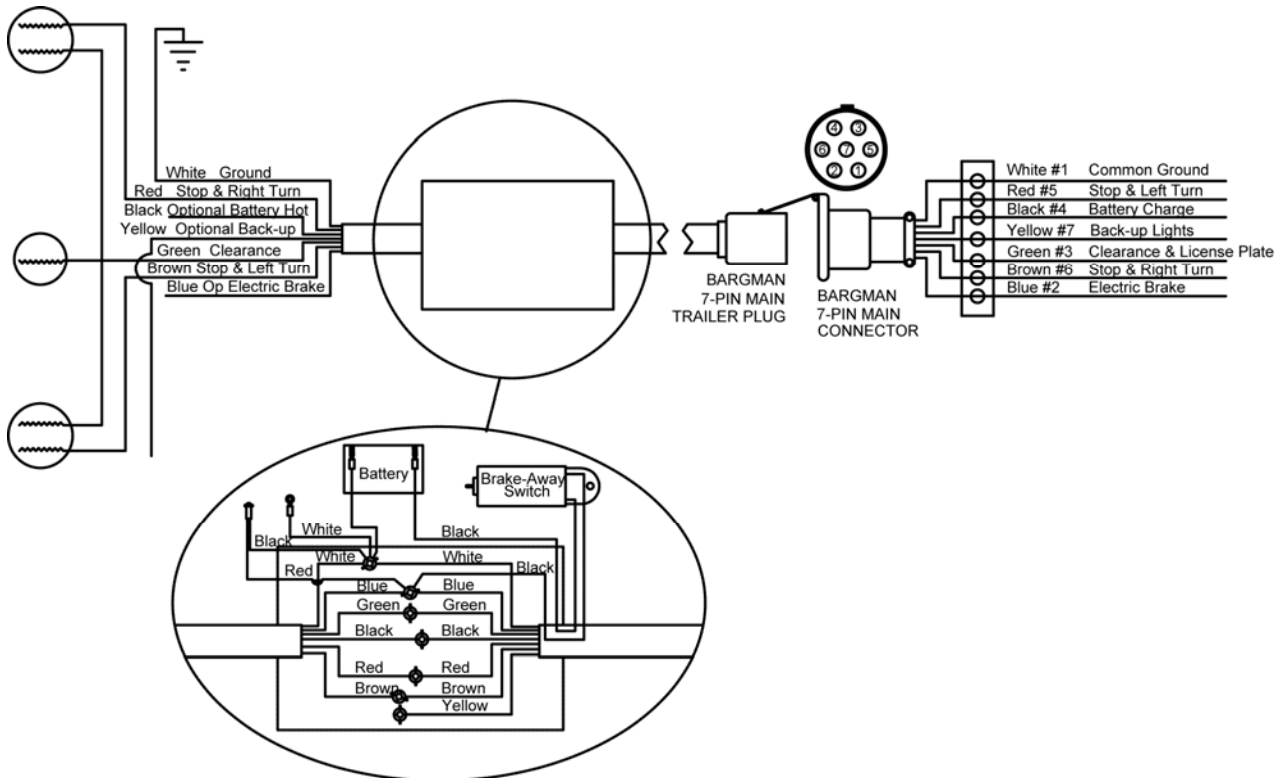

Bargman 7 Circuit Harness Connector

Section 9 - Technical Reference

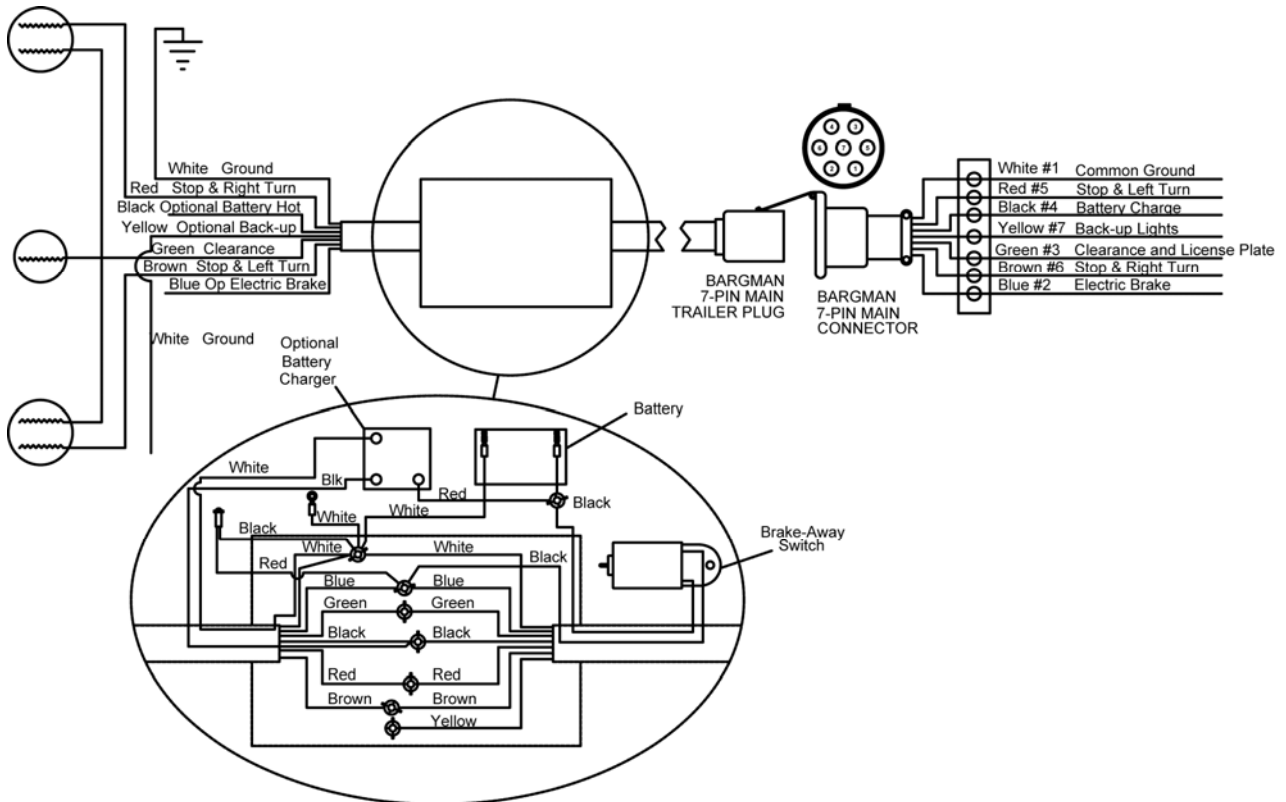

Bargman 7 Circuit Connector with Trickle Charger

9.2 HITCH SYSTEMS

The various components of trailer fastening systems may be referred to in terms of “Class” depending on their load rating. The rating of hitch systems on tow vehicles also considers whether the hitch only carries the tongue weight (for example, a ball hitch, which is also referred to as a Weight Carrying Hitch), or if it distributes the tongue weight to all of the tow vehicle wheels (also referred to as a Weight Distributing Hitch).

Your hitch or hitch ball may carry a “class” rating instead of a pound rating. This chart may be used to cross reference hitch/ball classification with trailer weight and tongue weight.

Hitch Classification

Class	Type of Hitch	Maximum Towed Weight	Maximum Tongue Weight
Class 1	Weight Carrying Hitch	up to 2,000 pounds	up to 200 pounds
Class 1	Weight Dist. Hitch	up to 2,000 pounds	up to 300 pounds
Class 2	Weight Carrying Hitch	up to 3,500 pounds	up to 300 pounds
Class 2	Weight Dist. Hitch	up to 3,500 pounds	up to 500 pounds
Class 3	Weight Carrying Hitch	up to 5,000 pounds	300 to 500 pounds
Class 3	Weight Dist. Hitch	up to 7,500 pounds	up to 750 pounds
Class 4	Weight Dist. Hitch	up to 10,000 pounds	up to 1,000 pounds

Section 10 - WARRANTY

Haulmark Industries, Inc. provides you with a 3-year limited warranty which gives you specific legal rights. Please be sure that you read and understand our Warranty.

THREE YEAR LIMITED WARRANTY

Haulmark Industries, Inc., P.O. Box 281, Bristol, IN 46507 (Warrantor) warrants to the ORIGINAL CONSUMER (PURCHASER) for a period of THREE (3) YEARS from the date of purchase by PURCHASER (WARRANTY PERIOD), that the TRAILER (the PRODUCT) shall be free of DEFECTS in materials and workmanship attributable to Warrantor (WARRANTY). WARRANTY IS NOT TRANSFERABLE TO SECOND OWNER. Excluded from this three year Warranty are electrical, plumbing, windows, doors, seals, sealant, electrolysis exterior metal, fenders, undercoating and fiberglass parts which are warranted for a ONE (1) YEAR period from the date of purchase by the original Purchaser. Certain component and attachments are warranted separately by their respective Manufacturer.

ITEMS EXCLUDED FROM WARRANTY

Warrantor is not responsible for claims relating to the following: (1) Product rental; (2) Defacing: scratches, dents, chips, tears, and defacing on any surface not caused by Warrantor; (3) Routine maintenance; (4) Damage from unauthorized repairs, abuse, misuse or neglect - including damage from heavy snow accumulation; (5) Damage caused from improper hitch ball or tow vehicle hook up; (6) Damage to the contents of any Product, regardless of cause; (7) Damages caused by loose or improperly torqued lug nuts; (8) Decals or graphics regardless of cause; (9) Off road usage; (10) Tow vehicle wiring; (11) Tire alignment; (12) Before making any alteration to your trailer, contact your dealer or Haulmark Industries, Inc. at 800-348-7530 and describe the alteration you are contemplating. Alteration of the trailer structure or modification of mechanical, electrical, plumbing, heating or other systems on your trailer must be performed only by qualified technicians who are familiar with the system as installed on your trailer. Warrantor reserves the right for final determination whether or not the product has been abused or misused by the Purchaser.

WARRANTOR'S OBLIGATION

Warrantor may elect to remedy all defects in materials and workmanship by repair. This is the only remedy available to Purchaser. All defective products shall be delivered to an authorized Haulmark dealer/repair center. Warrantor will not be obligated, in any way, to pay for any repairs made without specific prior approval. The repair facility will remedy all defects within a reasonable time, not to exceed (60) sixty days after delivery by Purchaser.

PURCHASER'S OBLIGATIONS - HOW TO GET WARRANTY SERVICE

Purchaser must notify his/her selling dealer of any defects in material or workmanship within (30) thirty days from the date of discovery within the warranty period. It is the selling dealer's responsibility to notify the Warrantor of any warrantable issues and to request authorization and replacement warranty parts. The Purchaser is required to complete and return to Warrantor the attached warranty registration card within

(15) fifteen days of product purchased to obtain Warranty service. Warranty will not apply if warranty registration card is not on file. Purchaser is responsible for all costs, towing, and transportation charges incurred to obtain Warranty service. If selling dealer is not available, then contact any authorized Haulmark dealer/repair center.

LIMITATION OF LIABILITY

Warrantor excludes liability, whether based on contract or Tort (including negligence), for any damages to purchaser or Any other party other than as described in this warranty or any Punitive, special, indirect, incidental or consequential damages Of any kind or for loss of revenue profits, loss of business or other financial loss arising out of or in connection with the sale, maintenance, use or failure of the product, even if warrantor has been advised of the possibility of such damages. This disclaimer of liability shall not be affected even if any remedy provided for herein fails its essential purpose.

DISCLAIMER OF IMPLIED WARRANTIES

Section 10 -Warranty

Warrantor makes no express or implied warranties other than as specifically set out in this warranty. Except for the express limited warranty set forth herein, the product is sold “as is” and there are no implied warranties of merchantability, fitness for a particular purpose, compliance with description and non-infringement in connection with any sale. This limited warranty does not cover failure of the product resulting from causes other than product defects, including but not limited to improper maintenance or use or any other such cause. If any provision of this Warranty is held to be illegal or unenforceable by any court of competent jurisdiction, the remaining provisions shall remain effective. Some states do not allow the exclusion or limitation of implied warranties or the limitation of incidental or consequential damages for certain products supplied to consumers or the limitation of liability for personal injury, so the limitations and exclusions above may be limited in their application. When the implied warranties cannot be excluded in their entirety, they will be limited to the duration of the written express warranty.

DESIGN CHANGES

Warrantor reserves the right to change the design of its Products from time to time without notice and with no obligation to make corresponding changes in its Products previously manufactured.

LEGAL REMEDIES OF PURCHASER

This warranty gives you specific legal rights, and you may have Other rights which may vary from state to state. No action to enforce this Warranty shall be commenced later than six (6) months after the discovery of any defect or after expiration of the Warranty Period.